



पुर्णा International School

Shree Swaminarayan Gurukul, Zundal

Class – XII

Subject: Physics

Experiment (2020_21)

Exp. No	Aim
Section – A	
1	To determine resistivity of two / three wires by plotting a graph for potential difference versus current.
2	To find resistance of a given wire / standard resistor using metre bridge
3	To compare the EMF of two given primary cells using potentiometer.
4	To determine resistance of a galvanometer by half-deflection method and to find its figure of merit
Section - B	
5	To find the focal length of a convex lens by plotting graphs between u and v or between $1/u$ and $1/v$.
6	To find the focal length of a convex mirror, using a convex lens.
7	To determine angle of minimum deviation for a given prism by plotting a graph between angle of incidence and angle of deviation.
8	To draw the I-V characteristic curve for a p-n junction diode in forward bias and reverse bias.
Activities	
1	To measure resistance, voltage (AC/DC), current (AC) and check continuity of a given circuit using multimeter.
2	To assemble a household circuit comprising three bulbs, three (on/off) switches, a fuse and a power source
3	To assemble the components of a given electrical circuit
4	To identify a diode, an LED, a resistor and a capacitor from a mixed collection of such items.
5	To observe polarization of light using two Polaroids
6	To observe diffraction of light due to a thin slit

Experiment – 1

Aim

To determine the resistance per cm of a given wire by plotting a graph for potential difference versus current.

Apparatus/ Material Required

- A wire of unknown resistance
- Battery
- Voltmeter
- Milliammeter
- Rheostat
- Plug key
- Connecting wires
- Piece of sandpaper

Circuit Diagram

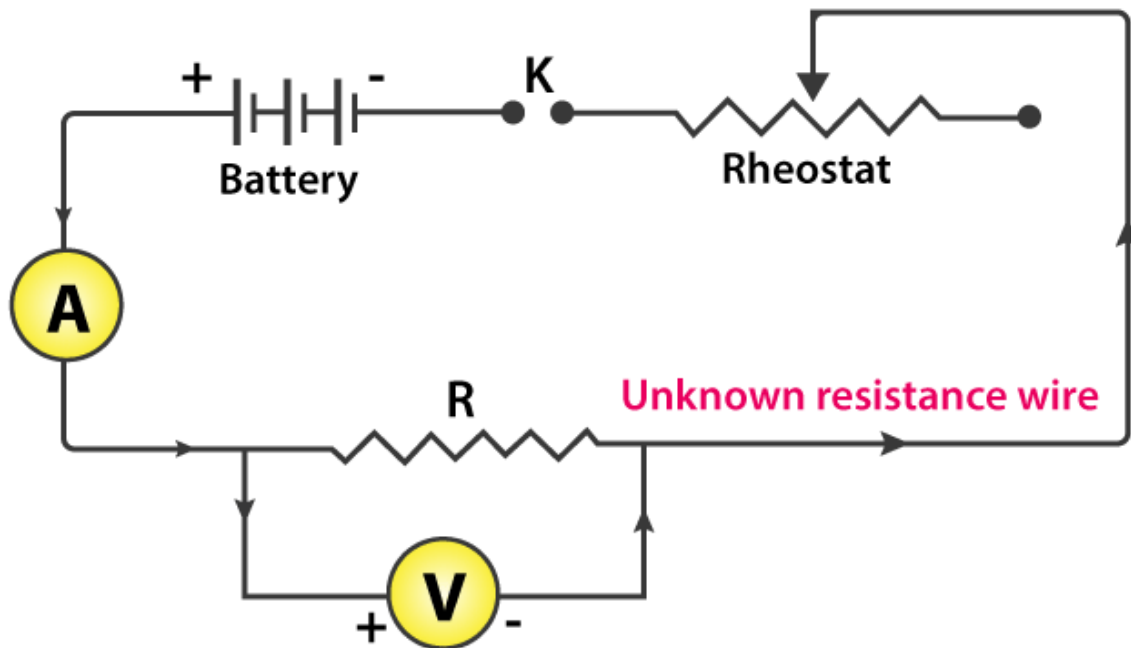

Theory

According to Ohm's law, the electric current flowing through a conductor is directly proportional to the potential difference across its ends, provided the physical state (pressure, temperature, and dimensions) of the conductor remains unchanged.

If I is the current flowing through the conductor and V is the potential difference across its end, then

$$V \propto I$$

and hence

$$V = RI$$

Where R is the constant of proportionality and is termed as the electrical resistance of the conductor.

Resistance R depends on the dimensions and material of the conductor. The relationship between the resistance of a material and its length and area of the cross-section is given by the formula

$$R = \rho \frac{l}{A}$$

Where ρ is the specific resistance or resistivity and is a characteristic of the material of the wire.

Observations

Range of ammeters = _____ mA to _____ mA

The Least count of ammeter = _____ mA

Range of voltmeter = _____ V to _____ V

The Least count of voltmeter = _____ V

The Least count of meter-scale = _____ m

Length of the given wire, l = _____ m

S. No	The applied potential difference (voltmeter reading V)	Current flowing through the wire (Milliammeter Reading A)

Calculations

- Plot a graph between the potential difference across the wire V and the current I flowing through the wire
- Determine the slope of the graph. The resistance of the given wire is then equal to the Reciprocal of the slope. From the graph, $R = BC/AB =$ _____ Ω
- Resistance per unit length of the wire = $R/l =$ _____ Ωm^{-1}

Result

The potential difference across the wire varies linearly with the current.

The resistance per unit length of the wire is ($R \pm \Delta R$) = _____ \pm _____ Ωm^{-1}).

Experiment – 2

Aim

To find resistance of a given wire using metre bridge and hence determine the resistivity (specific resistance) of its material.

Materials Required

1. A metre bridge
2. A Leclanche cell (battery eliminator)
3. A galvanometer
4. A resistance box
5. A jockey
6. A one-way key
7. A resistance wire
8. A screw gauge
9. A metre scale
10. A set square
11. Connecting wires
12. A piece of sandpaper

Theory

Metre bridge apparatus is also known as a slide wire bridge. It is fixed on the wooden block and consists of a long wire with a uniform cross-sectional area. It has two gaps formed using thick metal strips to make the **Wheatstone's bridge**.

Then according to Wheatstone's principle, we have:

$$XR = l / (100 - l)$$

The unknown resistance can be calculated as:

$$X = Rl / (100 - l)$$

Then the specific resistance of the material of the is calculated as:

$$\rho = \pi r^2 X / L$$

Where,

- L is the length of the wire
- r is the radius of the wire

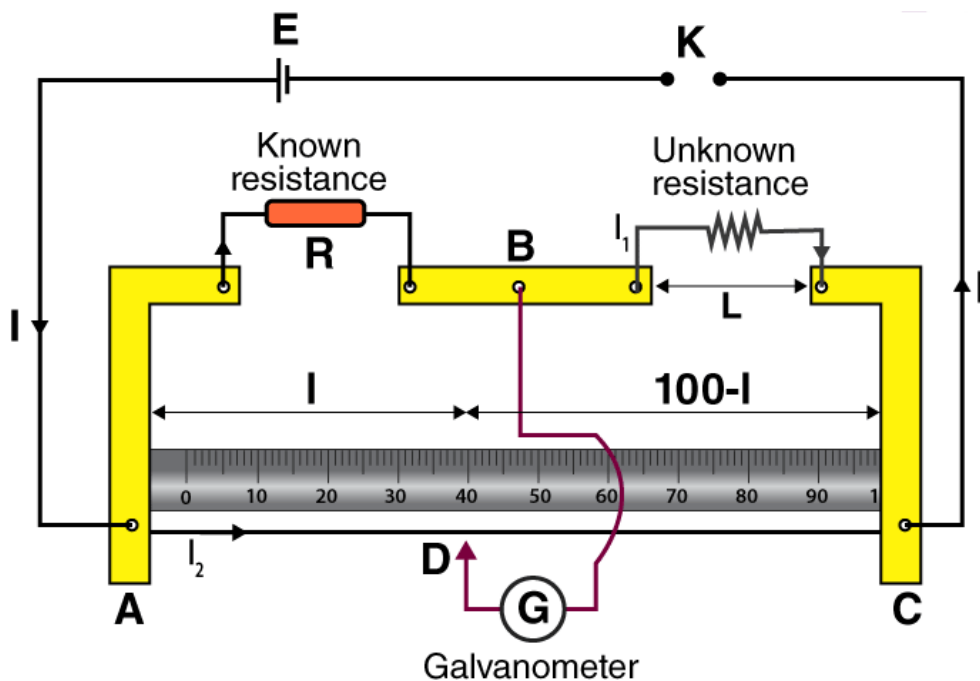

Circuit diagram - Metre bridge

Procedure

1. The arrangement of the apparatus should be as shown in the circuit diagram.
2. The wire whose resistance is to be determined should be connected in the right gap between C and B without any formation of loops.
3. The resistance box should be connected in the left gap between A and B .
4. All the other connections should be as shown in the circuit diagram.
5. Plug the key K in place of 2 -ohm resistance in the resistance box.
6. The jockey should be first touched gently to the left end and then to the right end of the bridge.
7. The deflections in the galvanometer should be in opposite directions and if it is in one direction then the circuit connections are not correct. Note the galvanometer deflection.
8. Let D be the null point where the jockey is touching the wire. The movement of the jockey should be gentle from left to the right of the galvanometer.
9. Take a 12 value from the resistance box should be taken such that when the jockey is nearly in the middle of the wire, there shouldn't be any deflection.
10. Note the position of D to know the length of $AD = l$.
11. Four sets of observations should be taken by changing the value of 12 .
12. Record the observations in a tabular form.
13. Stretch the resistance wire to find its length using a metre scale.
14. Using screw gauge measure the diameter of the wire at four different places keeping it in a mutually perpendicular direction.
15. Record the observations in the table

Observations

Length of given wire $L = \dots\dots\text{cm}$

Table for unknown resistance (X)

Resistance from box, R (Ohm)	Length AB = l (cm)	Length BC = (100-l) (cm)	Unknown Resistance X = $[R(100-l)]/L$ (Ohm)

Least count of the screw gauge

Pitch of screw gauge = $\dots\dots\text{mm}$

Total no. of divisions on the circular scale = $\dots\dots\dots$

\therefore L.C of the given screw gauge = $\text{pitch no. of divisions on the circular scale} = \dots\dots\text{mm}$

Zero error $e = \dots\dots\text{mm}$

Zero correction $c = -e = \dots\dots\text{mm}$

Radius of the resistance wire

Main scale reading (mm)	Circular scale reading	Total reading (diameter) (mm)	Mean D (mm)	Mean radius (D/2) (mm)

Calculations

Calculation for X

The value of l is determined from the position of D and recorded in column 3 of table 1.

Find length $(100 - l)$ cm and write in column 4.

Calculate X and write in column 5,

$$\text{Mean } X = \frac{X_1 + X_2 + X_3 + X_4}{4} = \dots\dots\text{ohm.}$$

Calculation for D

$$\text{Mean corrected diameter} = \frac{D_1(a) + D_1(b) + \dots + D_4(a) + D_4(b)}{8} = \dots\dots\text{mm} = \dots\dots\text{cm}$$

Calculation for specific resistance

Specific resistance of the material of the given wire,

$$\rho = \frac{X \cdot \pi D^2}{4L} = \dots\dots\text{ohm cm} = \dots\dots\text{ohm m}$$

Standard value of the specific resistance of the material of the given wire,

$$\rho_0 = \dots\dots\text{ohm.m}$$

$$\text{Percentage error} = \frac{\rho - \rho_0}{\rho_0} \times 100 = \dots\dots\%$$

Result

1. The value of unknown resistance $X = \dots\dots$
2. The specific resistance of the material of the given wire = $\dots\dots$
3. Percentage error = $\dots\dots$

Precautions

1. The connections should be neat, tight and clean.
2. Plugs should be tightly connected in the resistance box.
3. The movement of the jockey should be gentle and it shouldn't be rubbed.
4. The key K should be inserted only when the observations are to be taken.
5. The null point should be between 45cm and 55cm.
6. To avoid the error of parallax, the set square should be used to note the null point.
7. There shouldn't be any loops in the wire.
8. The diameter of the wire should be measured in two perpendicular directions that are mutual.

Sources of Error

1. The screws of the instrument might be loose.
2. The wire might be of non-uniform diameter.
3. There might be backlash error in the screw gauge.

Experiment – 3

Aim

To compare the EMF of two given primary cells (Daniel and Leclanche cells) with the help of a potentiometer.

Apparatus/Material Required

- Potentiometer
- Daniel Cell
- Leclanche Cell
- low resistance Rheostat
- Ammeter
- Voltmeter
- Galvanometer
- A one-way key
- A two-way key
- Set Square
- Jockey
- Resistance Box
- Connecting wires
- Piece of sandpaper

Theory:

- Using a voltmeter it is possible to measure only the potential difference between the two terminals of a cell, but using a potentiometer we can determine the value of emf of a given cell. Where E_1 and E_2 are EMFs of two cells, l_1 and l_2 are the balancing lengths when E_1 and E_2 are connected to the circuit respectively and ϕ is the potential gradient along the potentiometer wire.
- $E_1 / E_2 = \phi l_1 / \phi l_2 = l_1 / l_2$

Circuit Diagram

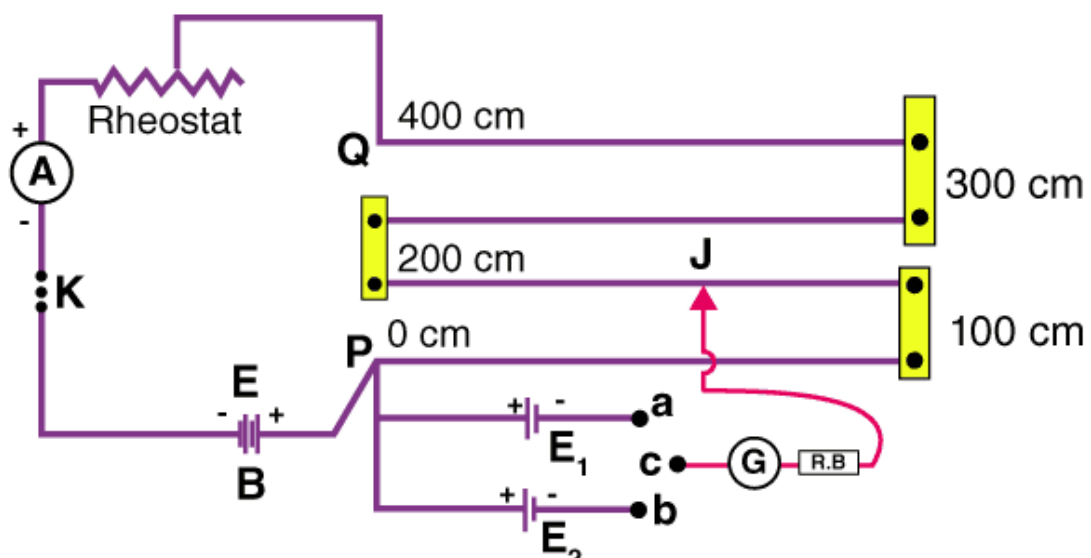

Calculations

1. For each observation, find mean I_1 and mean I_2 and record it $3c$ and $4c$ respectively.
2. Find E_1/E_2 , by dividing I_1 / I_2
3. Find the mean of E_1 / E_2

Result

The ratio of EMFs, $E_1 / E_2 \cong$ _____.

Experiment – 4

Aim

To determine resistance of a galvanometer by half-deflection method and to find its figure of merit.

Apparatus

A weston type galvanometer, a voltmeter, a battery or battery eliminator, two (10,000 Ω and 200 Ω) resistance boxes, two one-way keys, a rheostat, a screw gauge, a metre scale, an ammeter of given range, connecting wires and a piece of sand paper.

Theory

(i) The resistance of the given galvanometer as found by half deflection method

$$G = \frac{R \cdot S}{R - S} \quad \dots(1)$$

where R is the resistance connected in series with the galvanometer and S is the shunt resistance.

(ii) The figure of merit, $k = \frac{E}{(R + G)\theta}$... (2)

where E is the e.m.f. of the cell and θ is the deflection produced with resistance R .

(iii) The maximum current that can pass through the galvanometer, $I_g = nk$... (3)

where n is the total number of divisions on the galvanometer scale on either side of zero.

Circuit diagram

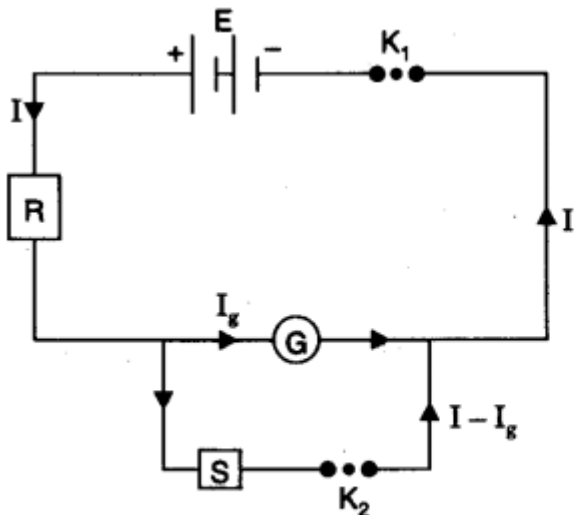

Resistance of galvanometer.

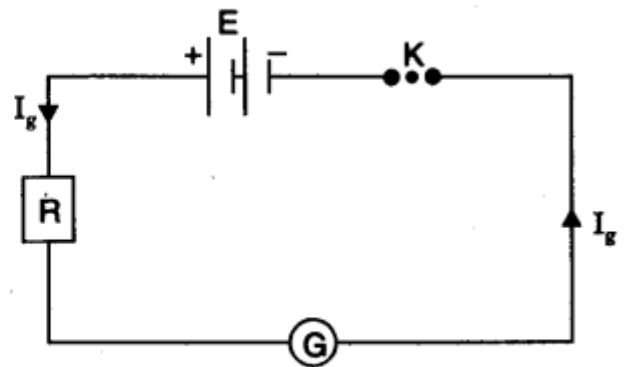

Figure of merit.

Procedure

(a) Resistance of galvanometer by half deflection method

1. Make the connections accordingly as shown in circuit diagram.
2. See that all plugs of the resistance boxes are tight.
3. Take out the high resistance (say 2000Ω) from the resistance box R and insert the key K_1 only.
4. Adjust the value of R so that deflection is maximum, even in number and within the scale.
5. Note the deflection. Let it be θ .
6. Insert the key also and without changing the value of R, adjust the value of S, such that deflection in the galvanometer reduces to exactly half the value obtained in step 5 i.e., $\theta/2$.
7. Note the value of resistance S.
8. Repeat steps 4 to 7 three times taking out different values of R and adjusting S every time.

(b) Figure of merit

9. Take one cell of the battery (battery eliminator) and find its E.M.F. by a voltmeter by connecting +ve of the voltmeter with +ve of the cell and -ve of voltmeter with -ve of the cell. Let it be E.
10. Make connections as in circuit diagram.
11. Adjust the value of R to obtain a certain deflection θ (say 30 divisions) when the circuit is closed.
12. Note the values of resistance R and deflection θ .
13. Now change the value of R and note the galvanometer deflection again.
14. Repeat the steps 9 to 13 with both cells of the battery with different voltages like 2, 4, 6, 8, volts from battery eliminator.
15. Find the figure of merit k using the formula.

Observations and Calculations

1. Table for resistance of the galvanometer by half deflection method

Serial No. of Obs	Resistance R (ohm)	Deflection in the Galvanometer θ	Shunt resistance S (ohm)	Half deflection $\frac{\theta}{2}$	Galvanometer resistance $G = \frac{RS}{R-S}$ (ohm)
(1)	(2)	(3)	(4)	(5)	(6)
1.					
2.					
3.					
4.					

2. Table for figure of merit

Serial No. of Obs	Number of cells (Battery eliminator)	e.m.f. of the cells E(V) or reading of battery eliminator	Resistance from R.B. R (ohm)	Deflection θ (div.)	Figure of merit $k = \frac{E}{(R + G)\theta}$
(1)	(2)	(3)	(4)	(5)	(6)
1.					
2.					
3.					
4.					

Number of divisions in the galvanometer scale, $n = \dots\dots$

1. Calculation for G

(i) Calculate G , using formula, $G = \frac{RS}{R - S}$ and write it in column 6 of Table 1.

(ii) Take mean of values of G recorded in column 6 of Table 1.

2. Calculation for k

(i) Calculate k , using formula, $k = \frac{E}{(R + G)\theta}$ and write it in column 6 of Table 2.

(ii) Take mean of values of k recorded in column 6 of Table 2.

Result

1. Resistance of given galvanometer = $\dots\dots\dots \Omega$
2. Figure of merit of given galvanometer = A/dn .

Precautions

1. All the connections should be neat, clean and tight.
2. All the plugs in resistance boxes should be tight.
3. The e.m.f. of cell or battery should be constant.
4. Initially a high resistance from the resistance box (R) should be introduced in the circuit (otherwise for small resistance an excessive current will flow through the galvanometer or ammeter can be damaged).

Sources of error

1. The screws of the instruments may be loose.
2. The plugs of resistance boxes may not be clean.
3. The e.m.f. of battery may not be constant.
4. The galvanometer divisions may not be of equal size.

Experiment – 5

Aim

To find, the focal length of a convex lens by plotting graphs between u and v or between $1/u$ and $1/v$.

Apparatus

An optical bench with three uprights (central upright fixed, two outer uprights with lateral movement), a convex lens with lens holder, two optical needles, (one thin, one thick) a knitting needle and a half metre scale.

Theory

The relation between u , v and f for a convex lens is

$$\frac{1}{f} = \frac{1}{v} - \frac{1}{u} \Rightarrow \frac{1}{f} = \frac{u-v}{uv} \Rightarrow f = \frac{uv}{u-v}$$

where,

f = focal length of convex lens

u = distance of object needle from optical centre of the lens

v = distance of image needle from optical centre of the lens.

Ray diagram

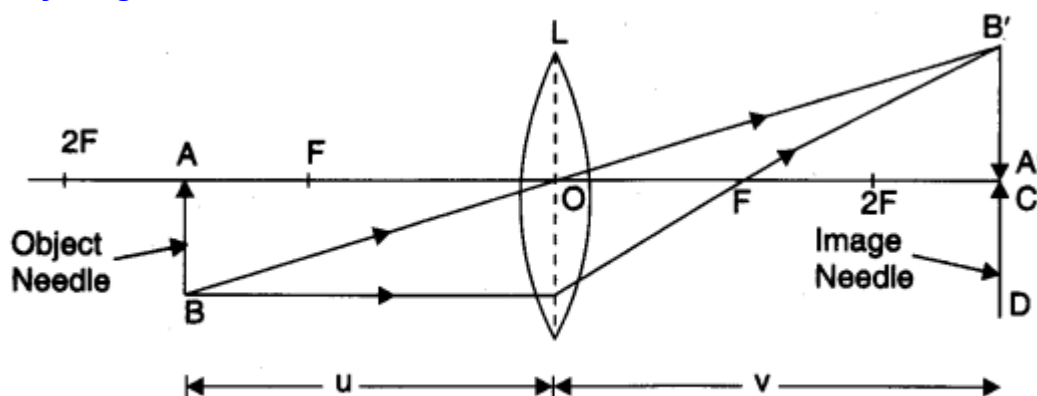

Fig. Focal length of convex lens.

Procedure

To determine rough focal length

1. Mount the concave mirror in mirror holder.
2. Go out in the open and face the mirror towards distant tree or building.
3. Obtain the image of the tree or the building on a white painted wall (screen) and move the mirror forward and backward to get a sharp image on the wall.
4. Measure the distance between the mirror and the wall (screen). This will be equal to the rough focal length of the mirror.

To set the lens

5. Clamp the holder with lens in a fixed upright and keep the upright at 50 cm mark.

6. Adjust the lens such that its surface is vertical and perpendicular to the length of the optical bench.
7. Keep the upright fixed in this position throughout.

To set the object needle

8. Take the thin optical needle as object needle (O). Mount it in outer laterally moveable upright near zero end.
9. Move the object needle upright and clamp it at a distance (in full cms) nearly 1.5 times the obtained rough focal length of the lens.
10. Adjust height of the object needle to make its tip lie on horizontal line through the optical centre of the lens.
11. Note the position of the index mark on the base of the object needle upright.

To set the image needle

12. With left eye closed, see with the right open eye from the other end of the optical bench. An inverted and enlarged image of the object needle will be seen. Tip of the image must lie in the middle of the lens.
13. Mount the thick optical needle (image needle) in the fourth upright near the other end of the optical bench.
14. Adjust the height of the image needle so that its tip is seen in line with the tip of the image when seen with right open eye.
15. Move the eye towards right. The tips will get separated. The image tip and the image needle tip have parallax.
16. Remove the parallax tip to tip.
17. Note the position of the index mark on base of the image needle upright.
18. Record the position of the index marks on the base of upright of the lens, the object needle and the image needle in the table against observation 2.

To determine index correction

19. Find the index correction for distance between optical centre of lens and tip of the object needle and also for distance between optical centre of lens and tip of the image needle as described.

To get more observations

20. Move object needle upright towards mirror in steps of 1 cm to get observation 2 and 1. Repeat the experiment.

Observations

Rough focal length of the given convex lens =cm

Actual length of the knitting needle $x = \dots\dots\dots$ cm

Observed distance between the object needle and the lens when knitting needle is placed between them $y = \dots\dots\dots$ cm

Observed distance between the image needle and the lens when knitting needle is placed between them $z = \dots\dots\dots$ cm

Index correction for the object distance u , $x - y = \dots\dots\dots$ cm

Index correction for the image distance v , $x-z = \dots\dots$ cm

Table for $u, v; \frac{1}{u}$ and $\frac{1}{v}$

Serial No. of Obs.	Position of			Observed distance		Corrected distance		$\frac{1}{u}$ (cm^{-1}) (5)	$\frac{1}{v}$ (cm^{-1}) (6)
	Object needle A (cm) (2a)	Lens O (cm) (2b)	Image needle C (cm) (2c)	OA = u (cm) (3a)	OC = v (cm) (3b)	u (cm) (4a)	v (cm) (4b)		
	(1)	(2a)	(2c)	(3a)	(3b)	(4a)	(4b)		
1.									
2.									
3.									
4.									
5.									
6.									

Calculations

Calculations of focal length by graphical methods:

(i) $u-v$ Graph. Select a suitable but the same scale to represent u along X' -axis and v along Y -axis. According to sign conventions, in this case, u is negative and v is positive. Plot the various points for different sets of values of u and v from observation table second quadrant. The graph comes out to be a rectangular hyperbola as shown in graph between u and v .

Draw a line OA making an angle of 45° with either axis (i.e., bisecting $\angle YOX'$) and meeting the curve at point A . Draw AB and AC perpendicular on X' - and Y -axes, respectively.

be $(2f, 2f)$, because for a convex lens, when $u = 2f, v = 2f$.

Hence, $AB = AC = 2f$ or $OC = OB = 2f$

$$\therefore f = \frac{OB}{2} \text{ and also } f = \frac{OC}{2}$$

\therefore Mean value of $f = \dots\dots$ cm

Result

The focal length of the given convex lens as determined from

1. focal length from $f = \frac{vu}{u-v}$

2. $(u-v)$ graph = $\dots\dots$ cm

3. $\left(\frac{1}{u} - \frac{1}{v}\right)$ graph = $\dots\dots$ cm

and 4. $(u-v)$ graph = $\dots\dots$ cm.

Precautions

1. Tips of the object and image needles should lie at the same height as the centre of the lens.
2. Parallax should be removed from tip to tip by keeping eye at a distance at least 30 cm away from the needle.
3. The object needle should be placed at such a distance that only real, inverted image of it is formed.
4. Index correction for u and v should be applied.

Sources of error

1. The uprights may not be the vertical.
2. Parallax removal may not be perfect.

Experiment – 6

Aim

To find the focal length of a convex mirror, using a convex lens.

Apparatus

An optical bench with four uprights (two fixed uprights in middle, two outer uprights with lateral movement), convex lens (20 cm focal length), convex mirror, a lens holder, a mirror holder, two optical needles, (one thin, one thick) a knitting needle, and a half metre scale.

Theory

$$\text{Focal length of a convex mirror } f = \frac{R}{2}$$

where R = radius of curvature of the mirror.

Ray Diagram

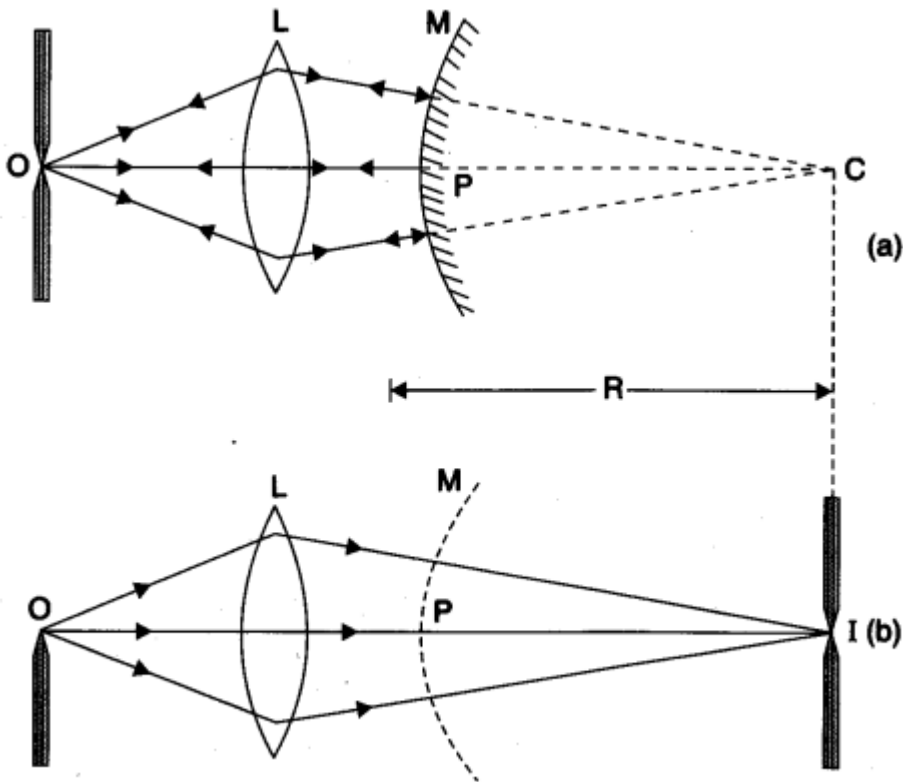

Fig. Focal length of convex mirror.

Procedure

To determine rough focal length of convex lens

1. To set the lens
2. Clamp the holder with lens in a fixed upright and keep the upright at 50 cm mark.

3. Adjust the lens such that its surface is vertical and perpendicular to the length of the optical bench.
4. Keep the upright fixed in this position throughout.

To set the object needle

5. Take the thin optical needle as object needle (O). Mount it in outer laterally move-able upright near zero end.
6. Move the object needle upright and clamp it at a distance (in full cm) nearly 1.5 times the obtained rough focal length of the lens.
7. Adjust height of the object needle to make its tip lie on horizontal line through the optical centre of the lens.
8. Note the position of the index mark on the base of the object needle upright.

To set the convex mirror

9. Clamp the holder with convex mirror in second fixed upright near the lens upright, keeping reflecting surface of the mirror towards lens.
10. Adjust the height of the mirror to make its pole lie on horizontal line through the optical centre of the lens.
11. Make the mirror surface vertical and perpendicular to the length of the optical bench (the principal axes of mirror and lens must coincide.)
12. Move towards zero end of the optical bench (where object needle is mounted).
13. Closing left eye, keep open right eye about 30 cm away from the tip of the object needle.
14. See the inverted image of the object needle (formed by reflection from the convex mirror).
15. Keep the eye in a position at which the tips of the inverted image and the object needle are seen simultaneously.
16. Adjust the height of the needle so that the two tips are seen in one line with right open eye.
17. Move the eye towards right. The tips will get separated. The tips have parallax.
18. Move the convex mirror back and forth till tip to tip parallax is removed.
19. Note the position of the index mark on the base of the convex mirror upright.

To set the image needle

20. Remove the convex mirror, keeping upright in its position.
21. With left eye closed, see with the right open eye from the other end of the optical bench. An inverted and enlarged image of the object needle will be seen. Tip of the image must lie in the middle of the lens.
22. Mount the thick optical needle (image needle) in the fourth upright near the other end of the optical bench.
23. Adjust the height of the image needle so that its tip is seen in line with the tip of the image when seen with right open eye.
24. Move the eye towards right. The tips will get separated. The image tip and the image needle tip have parallax.
25. Remove the parallax tip to tip.

26. Note the position of the index mark on base of the image needle upright.

27. Record the position of the index marks in the table against observation 2.

To determine index correction

28. Find index correction for distance between pole of convex mirror and tip of the image needle as described.

Observations

Rough focal length of the convex lens =

Actual length of the knitting needle, x =

Observed distance between image needle I and back of the convex mirror

y =

∴ Index correction = $(x - y)$,

=

Result

The focal length of the given convex mirror = cm.

Precautions

1. Principal axis of the lens should be horizontal and parallel to the central line of the optical bench.
2. All the uprights should be vertical.
3. The tip of the needle, centre of the mirror and centre of the lens should be at the same height.
4. While removing the parallax, the eye should be kept at a minimum distance of 30 cm from the needle.
5. Tip to tip parallax should be removed.
6. Index correction should be applied between the image needle I and back surface of the convex mirror.
7. The convex mirror should be placed close to the convex lens.
8. For one set of observation, when the parallax has been removed for convex lens alone, the positions of the lens and needle O uprights should not be changed.

Sources of error

1. Focal length of lens may not be small.

Experiment – 7

Aim

To determine angle of minimum deviation for a given prism by plotting a graph between angle of incidence and the angle of deviation.

Apparatus

Drawing board, a white sheet of paper, prism, drawing pins, pencil, half-metre scale, office pins, graph paper and a protractor.

Theory

The refractive index (n) of the material of the prism is given by

$$n = \frac{\sin\left(\frac{A + D_m}{2}\right)}{\sin\left(\frac{A}{2}\right)}$$

where, D_m angle of minimum deviation and A angle of the prism.

Diagram

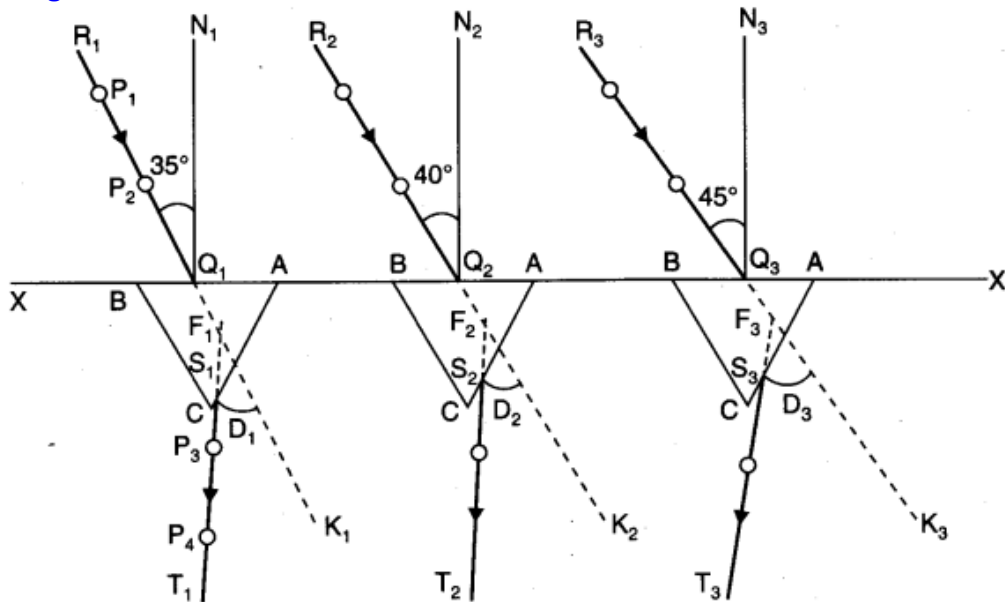

Fig. Refraction through prism at different angles.

Procedure

1. Fix a white sheet of paper on the drawing board with the help of drawing pins or tape.
2. Draw a straight line XX' parallel to the length of the paper nearly in the middle of the paper.
3. Mark points Q_1, Q_2, Q_3, \dots on the straight line XX' at suitable distances of about 5 cm.
4. Draw normals $N_1Q_1, N_2Q_2, N_3Q_3, \dots$ on points Q_1, Q_2, Q_3, \dots as shown in diagram.
5. Draw straight lines $R_1Q_1, R_2Q_2, R_3Q_3, \dots$ making angles of $35^\circ, 40^\circ, \dots 60^\circ$ (write value of the angles on the paper) respectively with the normals.
6. Mark one corner of the prism as A and take it as the edge of the prism for all the observations.
7. Put it prism with its refracting face AB in the line XX' and point Q_1 in the middle of AB .

8. Mark the boundary of the prism.
9. Fix two or more office pin P_1 and P_2 vertically on the line R_1Q_1 . The distance between the pins should be 10 mm or more.
10. Look the images of point P_1 and P_2 through face AC .
11. Close your left eye and bring open right eye in line with the two images.
12. Fix two office pins P_3 and P_4 vertically, and 10 cm apart such that the open right eye sees pins P_4 and P_3 and images of P_2 and P_1 in one straight line.
13. Remove pins P_3 and P_4 and encircle their pricks on the paper.
14. Repeat steps 7 to 13 with points Q_2, Q_3, \dots for $i = 40^\circ, \dots, 60^\circ$.

To measure D in different cases

15. Draw straight lines through points P_4 and P_3 (pin pricks) to obtain emergent rays $S_1T_1, S_2T_2, S_3T_3, \dots$
16. Produce $T_1S_1, T_2S_2, T_3S_3, \dots$ inward in the boundary of the prism to meet produced incident rays $R_1Q_1, R_2Q_2, R_3Q_3, \dots$ at points F_1, F_2, F_3, \dots
17. Measure angles $K_1F_1S_1, K_2F_2S_2, K_3F_3S_3, \dots$. These give angle of deviation D_1, D_2, D_3, \dots
18. Write values of these angles on the paper.

To measure A

19. Measure angle BAC in the boundary of the prism. This gives angle A .
20. Record your observations.

Observations

Angle of prism 'A' =

<i>Serial No. of Obs.</i>	<i>Angle of incidence $\angle i$</i>	<i>Angle of deviation $\angle D$</i>
1.	35°	
2.	40°	
3.	45°	
4.	50°	
5.	55°	
6.	60°	

Calculations

Plot a graph between angle of incidence $\angle i$ and angle of deviation $\angle D$ by taking $\angle i$ along X-axis and $\angle D$ along Y-axis. From this graph, find the value of single of minimum deviation D_m corresponding to the lowest point of the graph.

Let the value of angle of minimum deviation, $D_m = \dots$

Then,

$$n = \frac{\sin\left(\frac{A + D_m}{2}\right)}{\sin\left(\frac{A}{2}\right)}$$

Result

1. i-D graph indicates that as the angle of incidence (i) increases, the angle of deviation (D) first decreases, attains a minimum value (D_m) and then starts increasing for further increase in angle of incidence.
2. Angle of minimum deviation, $D_m = \dots\dots\dots$
3. Refractive index of the material of the prism, $n = \dots\dots\dots$

Precautions

1. The angle of incidence should lie between 35° - 60° .
2. The pins should be fixed vertical.
3. The distance between the two pins should not be less than 10 mm
4. Arrow heads should be marked to represent the incident and emergent rays.
5. The same angle of prism should be used for all the observations.

Sources of error

1. Pin pricks may be thick.
2. Measurement of angles may be wrong.

Experiment – 8

Aim

To draw the I-V characteristic curve of a p-n junction in forward bias and reverse bias.

Apparatus

A p-n junction (semi-conductor) diode, a 3 volt battery, a 50 volt battery, a high resistance rheostat, one 0-3 volt voltmeter, one 0-50 volt voltmeter, one 0-100 mA ammeter, one 0-100 μ A ammeter, one way key, connecting wires and pieces of sand paper.

Theory

Forward bias characteristics. When the p -section of the diode is connected to positive terminal of a battery and n-section is connected to negative terminal of the battery then junction is said to be forward biased. With increase in bias voltage, the forward current increases slowly in the beginning and then rapidly. At about 0.7 V for Si diode (0.2 V for Ge), the current increases suddenly. The value of forward bias voltage, at which the forward current increases rapidly, is called cut in voltage or threshold voltage. **Reverse bias characteristics.** When the p -section of the diode is connected to negative terminal of high voltage battery and n-section of the diode is connected to positive terminal of the same battery, then junction is said to be reverse biased.

When reverse bias voltage increases, initially there is a very small reverse current flow, which remains almost constant with bias. But when reverse bias voltage increases to sufficiently high value, the reverse current suddenly increases to a large value. This voltage at which breakdown of junction diode occurs (suddenly large current flow) is called zener breakdown voltage or inverse voltage. The breakdown voltage may start from one volt to several hundred volts, depending upon dopant density and the depletion layer.

Diagram

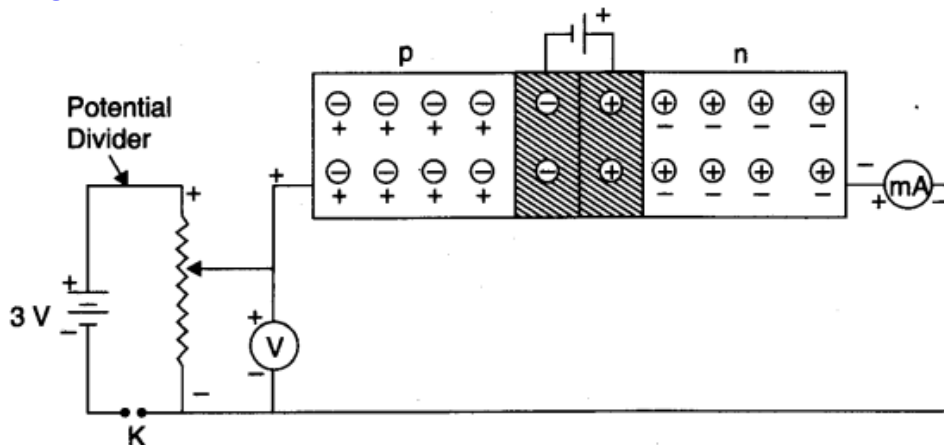

Fig. p-n junction diode—forward biased.

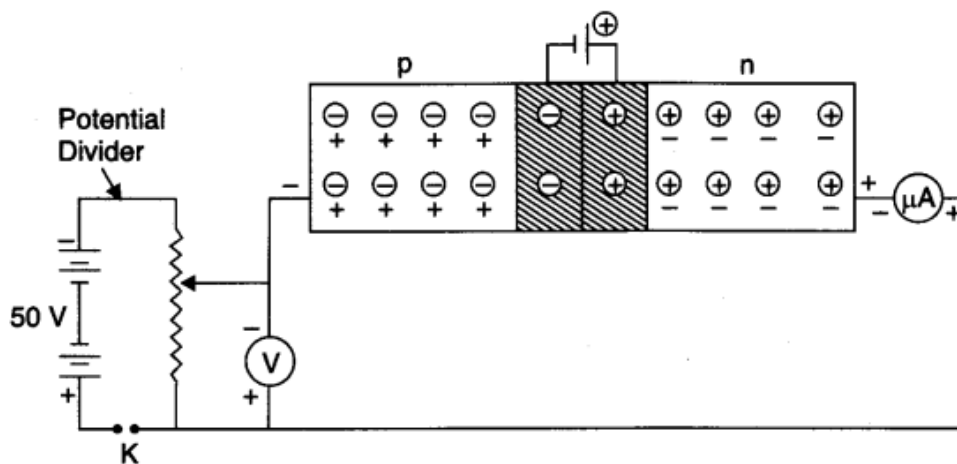

Fig. p-n junction diode—reverse biased.

Procedure

For forward-bias

1. Make circuit diagram as shown in diagram.
2. Make all connections neat, clean and tight.
3. Note least count and zero error of voltmeter (V) and milli-ammeter (mA).
4. Bring moving contact of potential divider (rheostat) near negative end and insert the key K. Voltmeter V and milli-ammeter mA will give zero reading.
5. Move the contact a little towards positive end to apply a forward-bias voltage (V_F) of 0.1 V. Current remains zero.
6. Increase the forward-bias voltage upto 0.3 V for Ge diode. Current remains zero, (It is due to junction potential barrier of 0.3 V).
7. Increase V_F to 0.4 V. Milli-ammeter records a small current.
8. Increase V_F in steps of 0.2 V and note the corresponding current. Current increases first slowly and then rapidly, till V_F becomes 0.7 V.
9. Make $V_F = 0.72$ V. The current increases suddenly. This represents "forward break-down" stage.
10. If the V_F increases beyond "forward breakdown" stage, the forward current does not change much. Now take out the key at once.
11. Record your observations as given ahead.

For reverse-bias

12. Make circuit diagram as shown in diagram.
13. Make all connections neat, clean and tight.
14. Note least count and zero error of voltmeter (V) and micro-ammeter (μ A).
15. Bring moving contact of potential divider (rheostat) near positive end and insert the key K. Voltmeter V and micro-ammeter μ A will give zero reading.
16. Move the contact towards negative end to apply a reverse-bias voltage (V_R) of 0.5 V, a feebly reverse current starts flowing.
17. Increase V_R in steps of 0.2 V. Current increases first slowly and then rapidly till V_R becomes 20 V. Note the current.
18. Make $V_R = 25$ V. The current increases suddenly. This represents "reverse break-down" stage. Note the current and take out the key at once.

Observations For forward-bias

Range of voltmeter	=V
Least count of voltmeter	=V
Zero error of voltmeter	=V
Range of milli-ammeter	=mA
Least count of milli-ammeter	=mA
Zero error of milli-ammeter	=mA

Table for forward-bias voltage and forward current

Serial No. of Obs. (1)	Forward-bias Voltage V_F (V) (2)	Forward current I_F (mA) (3)
1.	0	0
2.	0.1	0
3.	0.2	0
4.	0.3	0
5.	0.4	0.5
6.	0.6	1
7.	0.8	2
8.	1.0	3
9.	1.2	5
10.	1.4	7.5
11.	1.6	10
12.	1.8	15
13.	2.0	20
14.	2.2	25
15.	2.4	30

For reverse-bias

Range of voltmeter =V

Least count of voltmeter =V

Zero error of voltmeter =V

Range of micro-ammeter = μ A

Least count of micro-ammeter = μ A

Zero error of micro-ammeter =

2. Table for reverse-bias voltage and reverse current

Serial No. of Obs. (1)	Reverse-bias Voltage V_R (V) (2)	Reverse current I_R (μ A) (3)
1.	0	0
2.	5.0	1
3.	7.0	2
4.	9.0	3
5.	11.0	4
6.	13.0	5
7.	15.0	7
8.	17.0	9
9.	19.0	11
10.	21.0	13
11.	23.0	15
12.	25.0	25

Result

Junction resistance for forward-bias = 40 ohms

Junction resistance for reverse-bias = 2×10^6 ohms.

Precautions

1. All connections should be neat, clean and tight.
2. Key should be used in circuit and opened when the circuit is not being used.
3. Forward-bias voltage beyond breakdown should not be applied.
4. Reverse-bias voltage beyond breakdown should not be applied.

Sources of error

The junction diode supplied may be faulty.

Activity – 1

Aim

To measure resistance, voltage (AC/DC), current (AC) and check continuity of a given circuit using multimeter.

Apparatus and material

Apparatus. Three carbon resistors, one standard resistance coil, a battery eliminator with tapping (2 V, 4 V and 6 V), a step down transformer (6-0-6 V) with two tapping (2 V and 4 V), a resistor of 100 ohm, a plug key and multimeter.

Theory

Multimeter. It is a single measuring device acting as an Ammeter, a Voltmeter and an Ohmmeter. For this reason, it is also called **AVO** meter.

It can measure alternating as well as direct current and alternating as well as direct voltage in addition to resistance. For this purpose its panel is divided into five different sections. There are many ranges in each section so that it can measure from micro (10^{-6}) to mega (10^6) units. Rotation of a knob changes the section and the range in one section.

- Rotation of knob for change in ammeter range, brings shunt resistances of different values in circuit in parallel with the coil.

— Rotation of knob for change in voltmeter range, brings series resistances of different values in circuit in series with the coil.

— Rotation of knob for change in ohmmeter range, brings different resistances in circuit in series with the multimeter cell.

1. Carbon resistors are frequently used in electrical and electronic circuits and their values vary over a very wide range. A colour code is used to indicate the value of the resistance.

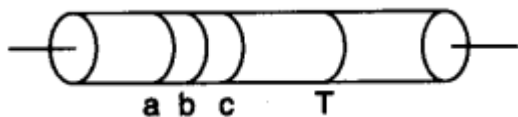

2. A carbon resistance has four different concentric coloured ring or bands on its surface. The first three bands a, b and c determine the value of the resistance and the fourth band d gives the percentage of accuracy called tolerance. The resistance of carbon resistor $R = (ab \times 10^c \pm T \%) \Omega$.

3. To read the value of carbon resistance, the following sentence is found to be of much more helpful.

B **B** **R** **O** **Y** **G** **r** **e** **a** **t** **B** **r** **i** **t** **a** **i** **n** **V** **e** **r** **y** **G** **o** **o** **d** **W** **i** **f** **e**
 0 1 2 3 4 5 6 7 8 9

The bold face letter B, B, R, O, Y, G, B, V, G and W, in above sentence correspond to the colours Black, Brown, Red, Orange, Yellow, Green, Blue, Violet, Grey and White respectively for *a* and *b*, while for the third *c*, they correspond to the multipliers 10^0 , 10^1 , 10^2 , 10^3 , 10^4 , 10^5 , 10^6 , 10^7 , 10^8 and 10^9 respectively.

4. The following table provides the colour code for the carbon resistors :

<i>Letter (helpful to memory)</i>	<i>Colour</i>	<i>Figure a. b.</i>	<i>Multiplier (c)</i>	<i>Colour (for the fourth band)</i>	<i>Tolerance T</i>
B	Black	0	10^0	Gold	5%
B	Brown	1	10^1	Silver	10%
R	Red	2	10^2	No colour	20%
O	Orange	3	10^3		
Y	Yellow	4	10^4		
G	Green	5	10^5		
B	Blue	6	10^6		
V	Violet	7	10^7		
G	Grey	8	10^8		
W	White	9	10^9		
	Gold		10^{-1}		
	Silver		10^{-2}		

(b) D.C. Voltage

1. Select a D.C. source of potential difference, 6 V battery eliminator or a battery.
2. Plug the probes black in com and red in +.
3. Select D.C. volt, by turning the selector switch to range 10 V D.C. volts,
4. Touch and press other ends of probes such that red is on battery terminal marked + and black on and not the reading.
5. Insert red probe in terminals marked 4 V, 2 V in succession and note readings.

(c) A.C. Volts

1. Turn the selector A.C. (200 Volt).
2. Touch and press the probes other ends to two terminals of A.C. source of potential drop and note the reading.
3. Use red probe in terminals 4 V and 2 V in succession and record the reading.

Precautions

1. Instructions for handling the multimeter should be gone through thoroughly as it is a very handy instrument and is likely to get damaged if carelessly or ignorantly used.
2. Select the appropriate parameter current, voltage or resistance to the measured and set it on appropriate range.
3. If range of the parameter measured is not known, start with maximum. For measuring V, never connect more than maximum 600 V.

Activity – 2

Aim

To assemble a household circuit comprising three bulbs, three (on/off) switches, a fuse and a power source.

Apparatus and material

Apparatus: No apparatus required in assembling a circuit.

Material: Three bulbs (6 V, 1W) each, fuse of 0.6 A, main switch a power supply (battery . eliminator), three (on/off) switches flexible connecting wire with red and black plastic covering, a fuse wire.

Supplementary: Main electric board with a two-pin socket and main switch.

Theory

Electricity supplied to us for domestic purposes is 220 V A.C. and 50 Hz. The household circuit, all appliances are connected in “parallel” with mains. The switches are connected in series with each appliances in live wire. 5 A switches are required for normal appliances like, bulbs, fluorescent tubes fans etc. 15 A sockets and switches are required for heavy load appliances ‘ like, refrigerator, air conditioner, geyser, hot plates etc. All appliances must have three wires called live, neutral and the earth. Total power consumption ‘P’ at a time

$$P = P_1 + P_2 + P_3 + \dots$$

where P_1 , P_2 , P_3 are the powers drawn by appliances.

To protect the appliances from damage when unduly high currents are drawn fuse of little higher rating, 10 to 20% higher than the current normally drawn by all appliances. For further safety, a suitable value MAINS FUSE like rating 32 A is connected in series with supply source.

Diagram

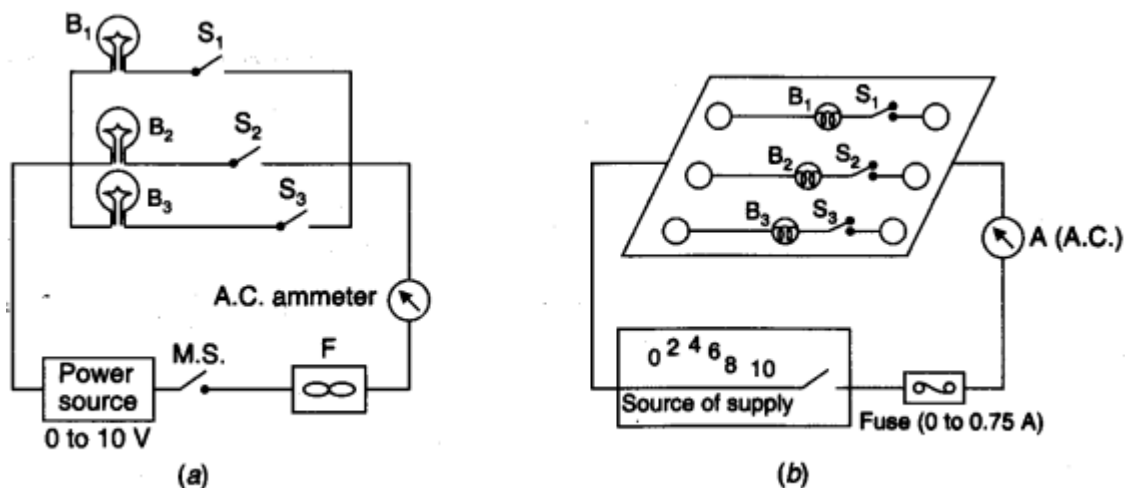

(a) Circuit diagram, (b) Actual layout.

Procedure

1. Connect the bulbs B_1 , B_2 and B_3 in series with switches S_1 , S_2 and S_3 respectively and connect each set of B-S in parallel with each other.
2. Connect main supply to a step-down transformer (battery eliminator) to get required voltage from 0 to 10 V (0, 2, 4, 6, 8 and 10 V).
3. Connect the mains fuse M.S. in series with the power supply (battery eliminator).
4. Connect an A.C. ammeter in series with the B-S set.
5. Connect one end of power supply to one end of B-S set.
6. Check the circuit one again to ensure that household circuit is complete.
7. Gradually increase the current to 0.75 A, the fuse must bum off at about 0.6 A.

Activity – 3

Aim

To assemble the components of a given electrical circuit.

Apparatus and material

Apparatus: A voltmeter and an ammeter of appropriate range, a battery, a rheostat, one way key.

Material: An unknown resistance or resistance coil, connecting wires, a piece of sand paper.

Diagram

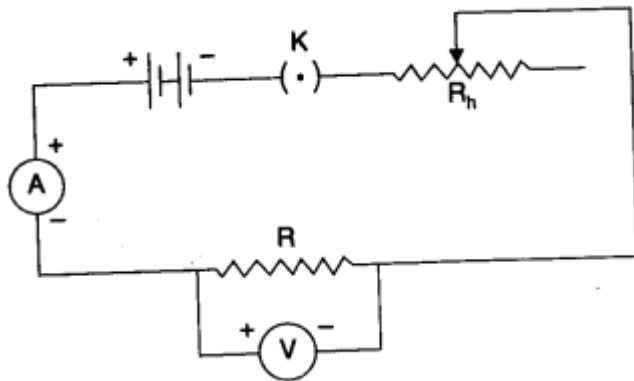

Procedure

1. Connect the components (Resistors, inductors etc.) in series with each other as shown in diagram and then in series with the battery.
2. Connect the ammeter in series with the circuit, to measure the current.
3. Connect the voltmeter in parallel to the resistor, to measure the potential difference.
4. Connect the switch in series with the battery.
5. Assembly of the electrical components in electric circuit is complete.

Activity – 4

Aim

To identify a diode, an LED, a transistor, an IC, a resistor and a capacitor from a mixed collection of such items.

Apparatus and material

Apparatus: Multimeter.

Material: Above mixed collection of items.

Theory

For identification, appearance and working of each item will have to be considered.

1. A diode is a two terminal device. It conducts when forward biased and does not conduct when reverse biased. It does not emit light while conducting. Hence, it does not glow.
2. A LED (light emitting diode) is also a two terminal device. It also conducts when forward biased and does not conduct when reverse biased. It emits light while conducting. Hence, it glow.
3. A transistor is a three terminal device. The terminals represent emitter (E), base (B) and collector (C).
4. An IC (integrated circuit) is a multi-terminal device in form of a chip. [See figure (UM 3482 IC Tone Generator)]
5. A resistor is a two terminal device. It conducts when either forward biased or reverse biased. (Infact there is no forward or reverse bias for a resistor). It conducts even when operated with A.C. voltage.
6. A capacitor is also a two terminal device. It does not conduct when either forward biased or reverse biased. When a capacitor is connected to a D.C. source, then multimeter shows full scale current initially but it decay to zero quickly. It is because that initially a capacitor draw a charge.

The components to be identified are shown in figure.

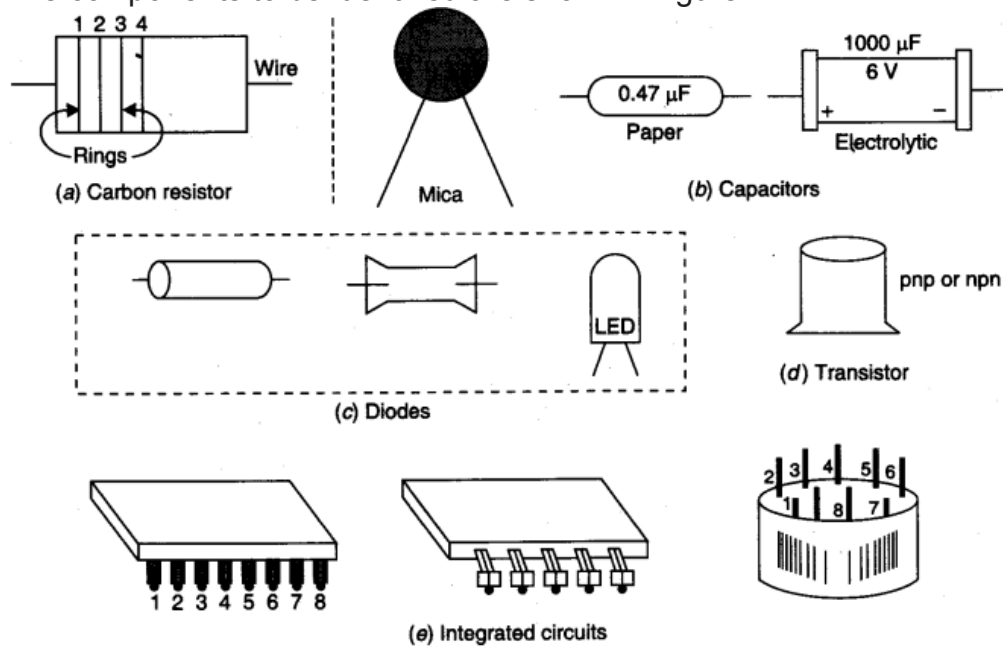

Fig. Some of the commonly available integrated circuits (ICS).

Procedure

1. If the item has four or more terminals and has form of a chip, it is an IC (integrated circuit).
2. If the item has three terminals, it is a transistor.
3. If the item has two terminals, it may be diode, a LED, a resistor or a capacitor.
To differentiate proceed as ahead.
4. Put the selector on resistance R of multimeter for checking the continuity. The probe metal ends are inserted in terminal marked on the multimeter as common and P (or + ve).

Activity – 5

Aim : To observe polarisation of light using two polaroids.

Apparatus

Thin glass sheet, a source giving monochromatic light beam with parallel rays, a polaroid.

Theory

When an unpolarised light is made incident on the interface of two transparent media at polarising angle, the refracted and reflected rays depart from each other at an angle of 90° . The reflected ray is completely plane polarised. It can be tested by a polaroid.

Diagram

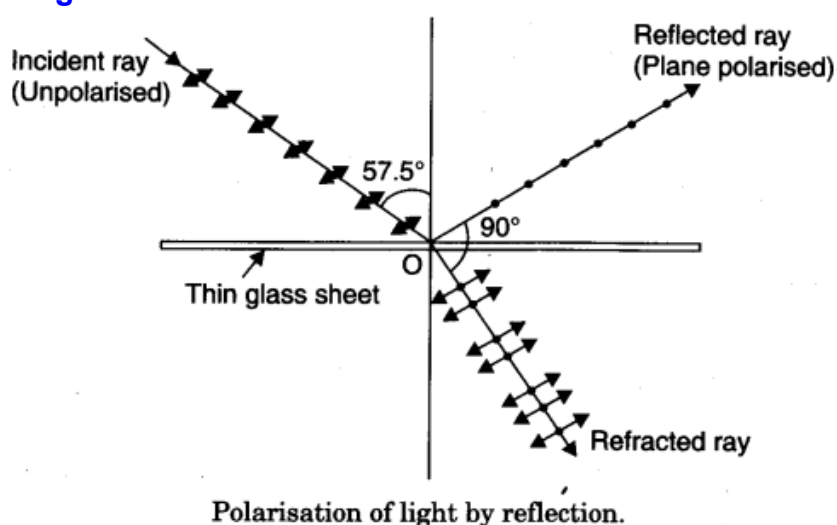

Procedure

Keep the thin glass sheet in a horizontal plane surface with a hole under the sheet. Take a beam of monochromatic light having parallel rays and make it incident on the upper face of the glass sheet.

Adjust the angle of incidence to 57.5° .

Observe the reflected rays and the refracted rays. They must make an angle of 90° with each other.

Testing of Polarisation

1. Take a polaroid (P) and keep it in between incident light and your eyes. Rotate it about an axis along incident ray. No change of intensity of light will be detected. It is so because the incident light is unpolarised.
2. Take the second polaroid (A) and place it at a proper distance between polaroid (P) and eye and parallel to it. Light is visible through them.
3. Now rotate the polaroid (A) ranging from 0° to 360° . Keeping the polaroid (P) fix and note the intensity of transmitted light.

4. When polaroid (A) and polaroid (P) at 90° than transmitted light through polaroid (A) will be zero

Result

When the two polaroids are parallel to each other light transmitted through it. But when they are perpendicular, there is no transmitted light. The light obtained through polaroid (P) is plane polarised. The light has transverse nature.

Activity – 6

Aim : To observe diffraction of light due to a thin slit.

Apparatus

Two razor blades, adhesive tapes, a screen a source of monochromatic light (laser pencil) black paper and a glass plate.

Theory

Diffraction is a phenomenon of bending of light around the corners or edges of a fine opening or aperture. Diffraction takes place when order of wavelength is comparable or small to the size of slit or aperture. The diffraction effect is more pronounced if the size of the aperture or the obstacle is of the order of wavelength of the waves. The diffraction pattern arises due to interference of light waves from different symmetrical point of the same wavefront. The diffraction pattern due to a single slit consists of a central bright band having alternate dark and weak bright bands of decreasing intensity on both sides.

For diffraction, $d \sin \theta = n\lambda$

Here d = size of aperture or slit

θ = angle of diffraction

n = order of diffraction

λ = wavelength of light.

Procedure

1. Fix the black paper on the glass plate by using adhesive.
2. Place two razor blades so that their sharp edges are parallel and extremely close to each other to form a narrow slit in between.

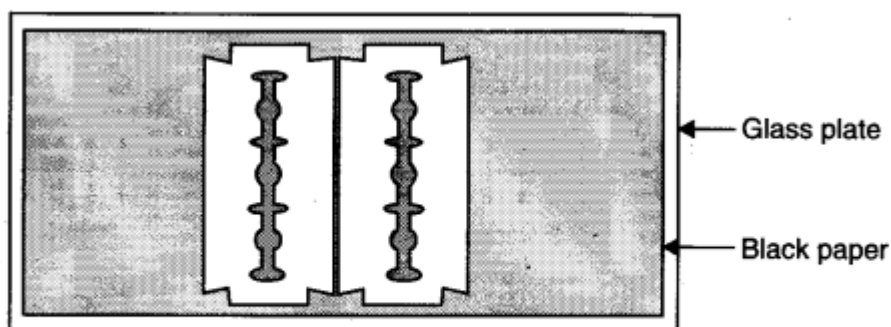

A thin slit made by using two razor blades, black paper and a glass plate.

3. Cut the small slit in between the sharp edges of blades and place at a suitable distance from a wall or screen of a dark room.
4. Throw a beam of light on the slit by the laser pencil.

Conclusion

When light waves are incident on a slit or aperture then it bends away (spread) at the corners of slit showing the phenomena of diffraction of light.

Precaution

1. Air gaps should not be left between glass plates and black paper.
2. The razor blades should be placed extremely closed as possible.
3. Diffraction pattern should be seen on a wall of a dark room.
4. A point source of monochromatic light like laser torch should be used
5. A diffraction pattern of alternate bright and dark bands is seen on the wall.

