



PUNA
INTERNATIONAL
SCHOOL

CLASS – 7

● SUBJECT - MATHS

● CHAPTER - 11

SAMPLE

NOTE-BOOK



Ex. 11.1

Question 1. The length and breadth of a rectangular piece of land are 500 m and 300 m respectively. Find:

(i) Its area.

(ii) The cost of the land, if 1 m^2 of the land costs Rs. 10,000.

Answer: Given: Length of a rectangular piece of land = 500 m and Breadth of a

rectangular piece of land = 300 m

(i) Area of a rectangular piece of land = Length x Breadth

$$= 500 \times 300 = 1,50,000 \text{ m}^2$$

(ii) Since, the cost of 1 m^2 land = Rs. 10,000

Therefore, the cost of 1,50,000 m^2 land = 10,000 x 1,50,000

$$= \text{Rs. } 1,50,00,00,000$$

Question 2. Find the area of a square park whose perimeter is 320 m.

Answer: Given: Perimeter of square park = 320 m

$$\Rightarrow 4 \times \text{side} = 320$$

$$\Rightarrow \text{side} = \frac{320}{4} = 80 \text{ m}$$

Now, Area of square park = side x side

$$= 80 \times 80 = 6400 \text{ m}^2$$

Thus, the area of Square Park is 6400 m^2 .

Question 3. Find the breadth of a rectangular plot of land, if its area is 440 m^2 and the length is 22 m. Also find its perimeter.

Answer: Area of rectangular park = 440 m^2

$$\Rightarrow \text{Length} \times \text{breadth} = 440 \text{ m}^2$$

$$\Rightarrow 22 \times \text{breadth} = 440 \Rightarrow \text{breadth} = \frac{440}{22} = 20 \text{ m}$$

Now, Perimeter of rectangular park = 2 (length + breadth)

$$= 2 (22 + 20)$$

$$= 2 \times 42 = 84 \text{ m}$$

Thus, the perimeter of rectangular park is 84 m.

Question 4. The perimeter of a rectangular sheet is 100 cm. If the length is 35 cm, find its breadth. Also find the area.

Answer: Perimeter of the rectangular sheet = 100 cm

$$\Rightarrow 2 (\text{length} + \text{breadth}) = 100 \text{ cm}$$

$$\Rightarrow 2(35 + \text{breadth}) = 100 \Rightarrow 35 + \text{breadth} = \frac{100}{2}$$

$$\Rightarrow 35 + \text{breadth} = 50 \Rightarrow \text{breadth} = 50 - 35$$

$$\Rightarrow \text{breadth} = 15 \text{ cm}$$

Now, Area of rectangular sheet = length x breadth

$$= 35 \times 15 = 525 \text{ cm}^2$$

Thus, breadth and area of rectangular sheet are 15 cm and 525 cm^2 respectively.

Question 5. The area of a square park is the same as of a rectangular park. If the side of the square park is 60 m and the length of the rectangular park is 90 cm, find the breadth of the rectangular park.

Answer: Given: The side of the square park = 60 m

The length of the rectangular park = 90 m

According to the question,

Area of square park = Area of rectangular park

$$\Rightarrow \text{side} \times \text{side} = \text{length} \times \text{breadth}$$

$$\Rightarrow 60 \times 60 = 90 \times \text{breadth}$$

$$\Rightarrow \frac{60 \times 60}{90}$$

$$\text{breadth} = \frac{440}{22} = 40 \text{ m}$$

Thus, the breadth of the rectangular park is 40 m.

Question 6. A wire is in the shape of a rectangle. Its length is 40 cm and breadth is 22 cm. If the same wire is rebent in the shape of a square, what will be the measure of each side. Also find which shape encloses more area?

Answer: According to the question, Perimeter of

square = Perimeter of rectangle

$$\Rightarrow 4 \times \text{side} = 2(\text{length} + \text{breadth})$$

$$\Rightarrow 4 \times \text{side} = 2(40 + 22) \Rightarrow 4 \times \text{side} = 2 \times 62$$

$$\Rightarrow \text{side} = \frac{2 \times 62}{4} = 31 \text{ cm}$$

Thus, the side of the square is 31 cm.

Now, Area of rectangle = length x breadth = $40 \times 22 = 880 \text{ cm}^2$ And Area of

square = side x side = $31 \times 31 = 961 \text{ cm}^2$

Therefore, on comparing, the area of square is greater than that of rectangle.

Question 7. The perimeter of a rectangle is 130 cm. If the breadth of the rectangle is 30 cm, find its length. Also, find the area of the rectangle.

$$\Rightarrow \text{Answer: Perimeter of rectangle} = 130 \text{ cm} \quad 2(\text{length} + \text{breadth}) = 130 \text{ cm}$$

$$\Rightarrow 2(\text{length} + 30) = 130 \Rightarrow \text{length} + 30 = \frac{130}{2}$$

$$\Rightarrow \text{length} + 30 = 65 \Rightarrow \text{length} = 65 - 30 = 35 \text{ cm}$$

Now area of rectangle = length x breadth = $35 \times 30 = 1050 \text{ cm}^2$

Thus, the area of rectangle is 1050 cm^2 .

Question 8. A door of length 2 m and breadth 1 m is fitted in a wall. The length of the wall is 4.5 m and the breadth is 3.6 m. Find the cost of white washing the wall, if the rate of white washing the wall is Rs. 20 per m^2 .

Answer: Area of rectangular door = length x breadth = 2 m x 1 m = $2 m^2$

Area of wall including door = length x breadth = 4.5 m x 3.6 m = $16.2 m^2$

Now, Area of wall excluding door

= Area of wall including door – Area of door

= $16.2 - 2 = 14.2 m^2$

Since,

The rate of white washing of $1 m^2$ the wall = Rs. 20

Therefore, the rate of white washing of $14.2 m^2$ the wall = 20×14.2

= Rs. 284

Thus, the cost of white washing the wall excluding the door is Rs. 284.

Ex. 11.2

Question 1. Find the area of each of the following parallelograms:

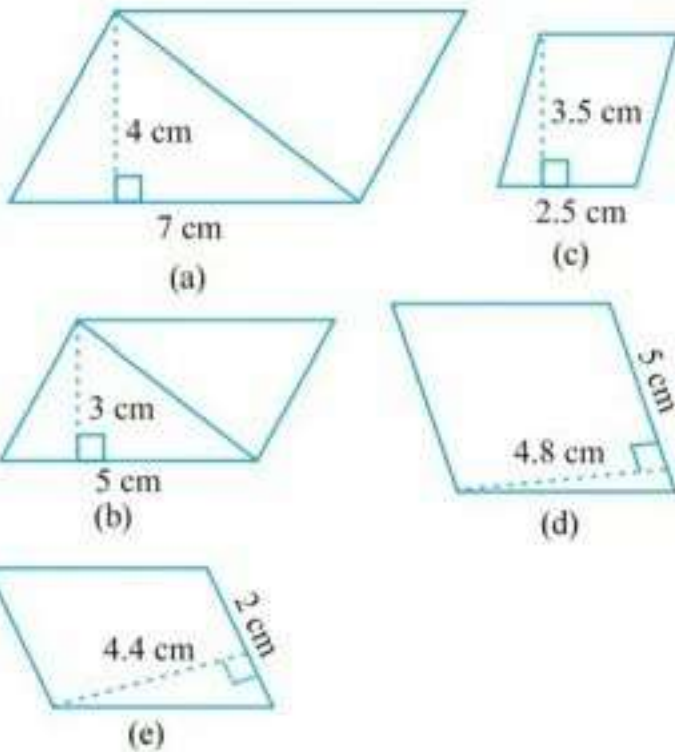

Answer: We know that the area of parallelogram = base x height

(a) Here base = 7 cm and height = 4 cm

$$\therefore \text{Area of parallelogram} = 7 \times 4 = 28 \text{ cm}^2$$

(b) Here base = 5 cm and height = 3 cm

$$\therefore \text{Area of parallelogram} = 5 \times 3 = 15 \text{ cm}^2$$

(c) Here base = 2.5 cm and height = 3.5 cm

$$\therefore \text{Area of parallelogram} = 2.5 \times 3.5 = 8.75 \text{ cm}^2$$

(d) Here base = 5 cm and height = 4.8 cm

$$\therefore \text{Area of parallelogram} = 5 \times 4.8 = 24 \text{ cm}^2$$

(e) Here base = 2 cm and height = 4.4 cm

$$\therefore \text{Area of parallelogram} = 2 \times 4.4 = 8.8 \text{ cm}^2$$

Question 2. Find the area of each of the following triangles:

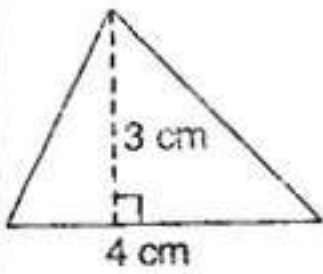

(a)

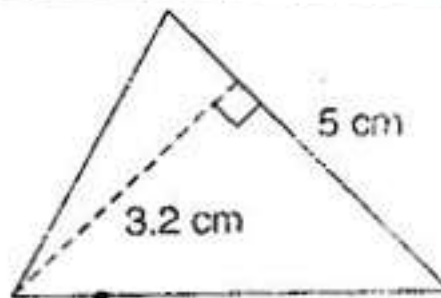

(b)

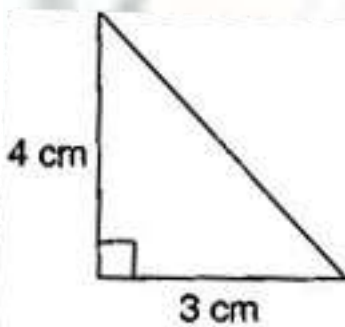

(c)

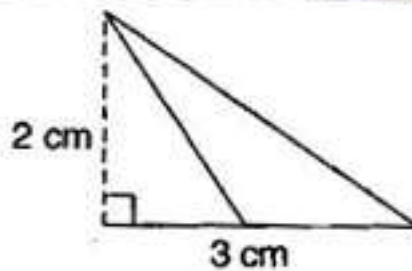

(d)

Answer: We know that the area of triangle = $\frac{1}{2} \times \text{base} \times \text{height}$

(a) Here, base = 4 cm and height = 3 cm

$$\therefore \text{Area of triangle} = \frac{1}{2} \times 4 \times 3 = 6 \text{ cm}^2$$

(b) Here, base = 5 cm and height = 3.2 cm

$$\therefore \text{Area of triangle} = \frac{1}{2} \times 5 \times 3.2 = 8 \text{ cm}^2$$

$$\therefore \text{Here, base} = 3 \text{ cm and height} = 4 \text{ cm Area of triangle} = \frac{1}{2} \times 3 \times 4 = 6 \text{ cm}^2$$

(d) Here, base = 3 cm and height = 2 cm

$$\therefore \text{Area of triangle} = \frac{1}{2} \times 3 \times 2 = 3\text{cm}^2$$

Question 3. Find the missing values:

| S. No. | Base | Height | Area of the parallelogram |
|--------|---------|--------|---------------------------|
| a. | 20 cm | | 246 cm ² |
| b. | | 15 cm | 154.5 cm ² |
| c. | | 8.4 cm | 48.72 cm ² |
| d. | 15.6 cm | | 16.38 cm ² |

Answer: We know that the area of parallelogram = base x height

(a) Here, base = 20 cm and area = 246 cm²

\therefore Area of parallelogram = base x height

$$\Rightarrow 246 = 20 \times \text{height} \Rightarrow \text{height} = \frac{246}{20} = 12.3 \text{ cm}$$

(b) Here, height = 15 cm and area = 154.5 cm²

\therefore Area of parallelogram = base x height

$$\Rightarrow 154.5 = \text{base} \times 15 \Rightarrow \text{base} = \frac{154.5}{15} = 10.3 \text{ cm}$$

(c) Here, height = 8.4 cm and area = 48.72 cm² Area of

\therefore parallelogram = base x height

$$\Rightarrow 48.72 = \text{base} \times 8.4 \Rightarrow \text{base} = \frac{48.72}{8.4} = 5.8 \text{ cm}$$

(d) Here, base = 15.6 cm and area = 16.38 cm² Area of

\therefore parallelogram = base x height

$$\Rightarrow 16.38 = 15.6 \times \text{height} \Rightarrow \text{height} = \frac{16.38}{15.6} = 1.05 \text{ cm}$$

Thus, the missing values are:

| S. No. | Base | Height | Area of the parallelogram |
|--------|----------------|----------------|---------------------------|
| a. | 20 cm | 12.3 cm | 246 cm ² |
| b. | 10.3 cm | 15 cm | 154.5 cm ² |
| c. | 5.8 cm | 8.4 cm | 48.72 cm ² |
| d. | 15.6 cm | 1.05 | 16.38 cm ² |

Question 4. Find the missing values:

| Base | Height | Area of triangle |
|-------|---------|-----------------------|
| 15 cm | --- | 87 cm ² |
| --- | 31.4 mm | 1256 mm ² |
| 22 cm | -- | 170.5 cm ² |

Answer: We know that the area of triangle = $\frac{1}{2}$ x base x height

In first row, base = 15 cm and area = 87 cm²

$$\therefore 87 = \frac{1}{2} \times 15 \times \text{height} \Rightarrow \text{height} = \frac{87 \times 2}{15} = 11.6 \text{ cm}$$

In second row, height = 31.4 mm and area = 1256 mm²

$$\therefore 1256 = \frac{1}{2} \times \text{base} \times 31.4 \Rightarrow \text{base} = \frac{1256 \times 2}{31.4} = 80 \text{ mm}$$

In third row, base = 22 cm and area = 170.5 cm²

$$\therefore 170.5 = \frac{1}{2} \times 22 \times \text{height} \Rightarrow \text{height} = \frac{170.5 \times 2}{22} = 15.5 \text{ cm}$$

Thus, the missing values are:

| Base | Height | Area of triangle |
|-------|---------|-----------------------|
| 15 cm | 11.6 cm | 87 cm ² |
| 80 mm | 31.4 mm | 1256 mm ² |
| 22 cm | 15.5 cm | 170.5 cm ² |

Question 5. PQRS is a parallelogram. QM is the height from Q to SR and QN is the height from Q to PS. If SR = 12 cm and QM = 7.6 cm. Find:

- (a) the area of the parallelogram PQRS
 (b) QN, if PS = 8cm

Answer: Given: SR = 12 cm, QM = 7.6 cm, PS = 8 cm.

(a) Area of parallelogram = base x height = 12 x 7.6 = 91.2 cm²

(b) Area of parallelogram = base x height

$$\Rightarrow 91.2 = 8 \times \text{QN} \Rightarrow \text{QN} = \frac{91.2}{8} = 11.4 \text{ cm}$$

Question 6. DL and BM are the heights on sides AB and AD respectively of parallelogram ABCD. If the area of the parallelogram is 1470 cm², AB = 35 cm and AD = 49 cm, find the length of BM and DL.

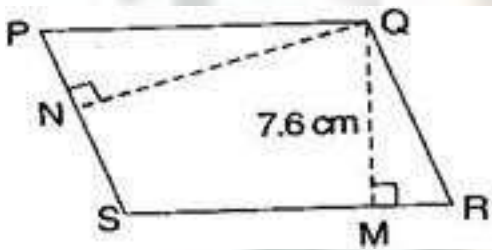

Answer: Given: Area of parallelogram = 1470 cm² Base

(AB) = 35 cm and base (AD) = 49 cm

Since Area of parallelogram = base x height

$$\Rightarrow 1470 = 35 \times \text{DL} \Rightarrow \text{DL} = \frac{1470}{35} = 42 \text{ cm}$$

Again, Area of parallelogram = base x height 1470 = 49 x BM

$$\Rightarrow \Rightarrow \frac{1470}{49}$$

$$BM = \quad = 30 \text{ cm}$$

Thus, the lengths of DL and BM are 42 cm and 30 cm respectively.

Question 7. $\triangle ABC$ is right angled at A. AD is perpendicular to BC. If AB = 5 cm, BC = 13 cm and AC = 12 cm, find the area of $\triangle ABC$. Also, find the length of AD.

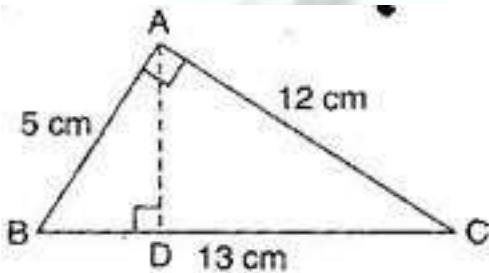

Answer: In right angled triangle BAC, AB = 5 cm and AC = 12 cm

$$\text{Area of triangle} = \frac{1}{2} \times \text{base} \times \text{height} = \frac{1}{2} \times AB \times AC = \frac{1}{2} \times 5 \times 12 = 30 \text{ cm}^2$$

Now, in $\triangle ABC$,

$$\text{Area of triangle ABC} = \frac{1}{2} \times BC \times AD$$

$$\Rightarrow 30 = \frac{1}{2} \times 13 \times AD \Rightarrow AD = \frac{30 \times 2}{13} = \frac{60}{13} \text{ cm}$$

Question 8. $\triangle ABC$ is isosceles with AB = AC = 7.5 cm and BC = 9 cm. The height AD from A to BC, is 6 cm. Find the area of $\triangle ABC$. What will be the height from C to AB i.e., CE?

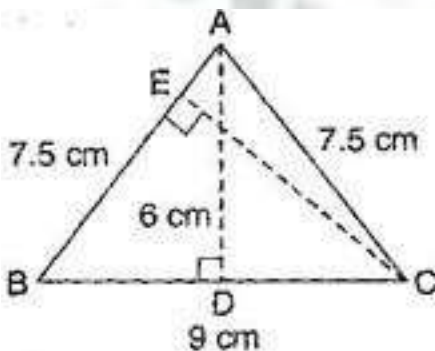

Answer: In $\triangle ABC$, AD = 6 cm and BC = 9 cm

$$\text{Area of triangle} = \frac{1}{2} \times \text{base} \times \text{height} = \frac{1}{2} \times BC \times AD = \frac{1}{2} \times 9 \times 6 = 27 \text{ cm}^2$$

Again, Area of triangle = $\frac{1}{2}$ x base x height = $\frac{1}{2}$ x AB x CE

$$\Rightarrow 27 = \frac{1}{2} \times 7.5 \times CE \Rightarrow CE = \frac{27 \times 2}{7.5} = 7.2 \text{ cm}$$

Thus, height from C to AB i.e., CE is 7.2 cm.

Ex. 11.3

Question 1. Find the circumference of the circles with the following radius:

(Take $\pi = \frac{22}{7}$)

- (a) 14 cm
- (b) 28 mm
- (c) 21 cm

Answer: (a) Circumference of the circle = $2\pi r = 2 \times \frac{22}{7} \times 14 = 88 \text{ cm}$

(b) Circumference of the circle = $2\pi r = 2 \times \frac{22}{7} \times 28 = 176 \text{ mm}$

(c) Circumference of the circle = $2\pi r = 2 \times \frac{22}{7} \times 21 = 132$ cm

Question 2. Find the area of the following circles, given that: $\left(\text{Take } \pi = \frac{22}{7}\right)$

(a) radius = 14 mm

(b) diameter = 49 m

(c) radius 5 cm

Answer: (a) Area of circle = $\pi r^2 = \frac{22}{7} \times 14 \times 14 = 22 \times 2 \times 14 = 616$ mm²

(b) Diameter = 49 m

\therefore radius = $\frac{49}{2} = 24.5$ m

\therefore Area of circle = $\pi r^2 = \frac{22}{7} \times 24.5 \times 24.5 = 22 \times 3.5 \times 24.5 = 1886.5$ m²

(c) Area of circle = $\pi r^2 = \frac{22}{7} \times 5 \times 5 = \frac{550}{7}$ cm²

Question 3. If the circumference of a circular sheet is 154 m, find its radius. Also find the area of the sheet. $\left(\text{Take } \pi = \frac{22}{7}\right)$

Answer: Circumference of the circular sheet = 154 m

$\Rightarrow 2\pi r = 154 \text{ m} \Rightarrow r = \frac{154}{2\pi}$

$\Rightarrow r = \frac{154 \times 7}{2 \times 22} = 24.5$ m

Now, Area of circular sheet = $\pi r^2 = \frac{22}{7} \times 24.5 \times 24.5 = 22 \times 3.5 \times 24.5 = 1886.5$ m²

Thus, the radius and area of circular sheet are 24.5 m and 1886.5 m² respectively.

Question 4. A gardener wants to fence a circular garden of diameter 21 m. Find the length of the rope he needs to purchase, if he makes 2 rounds of fence. Also, find the costs of the rope if it cost Rs. 4 per meter. $\left(\text{Take } \pi = \frac{22}{7}\right)$

Answer: Diameter of the circular garden = 21 m

\therefore $\frac{21}{2}$

Radius of the circular garden = m

$$\text{Now, Circumference of circular garden} = 2\pi r = 2 \times \frac{22}{7} \times \frac{21}{2} = 2 \times 11 \times 3 = 22 \times 3 = 66 \text{ m}$$

The gardener makes 2 rounds of fence

so the total length of the rope of fencing

$$= 2 \times 2\pi r = 2 \times 66 = 132 \text{ m}$$

Since the cost of 1 meter rope = Rs. 4

Therefore, cost of 132 meter rope = $4 \times 132 = \text{Rs. } 528$

Question 5. From a circular sheet of radius 4 cm, a circle of radius 3 cm is removed. Find the area of the remaining sheet. (Take $\pi = 3.14$)

Answer: Radius of circular sheet (R) = 4 cm and radius of removed circle (r) = 3 cm
Area of remaining sheet = Area of circular sheet – Area of removed circle

$$\begin{aligned} &= \pi R^2 - \pi r^2 = \pi (R^2 - r^2) \\ &= \pi (4^2 - 3^2) = \pi (16 - 9) = 3.14 \times 7 = 21.98 \text{ cm}^2 \end{aligned}$$

Thus, the area of remaining sheet is 21.98 cm^2 .

Question 6. Saima wants to put a lace on the edge of a circular table cover of diameter 1.5 m. Find the length of the lace required and also find its cost if one meter of the lace costs Rs. 15.

(Take $\pi = 3.14$)

Answer: Diameter of the circular table cover = 1.5 m Radius

\therefore of the circular table cover = $\frac{1.5}{2}$ m

$$\text{Circumference of circular table cover} = 2\pi r = 2 \times 3.14 \times \frac{1.5}{2} = 4.71 \text{ m}$$

Therefore the length of required lace is 4.71 m.

Now the cost of 1 m lace = Rs. 15

Then the cost of 4.71 m lace = $15 \times 4.71 = \text{Rs. } 70.65$

Hence, the cost of 4.71 m lace is Rs. 70.65.

Question 7. Find the perimeter of the adjoining figure, which is a semicircle including its diameter.

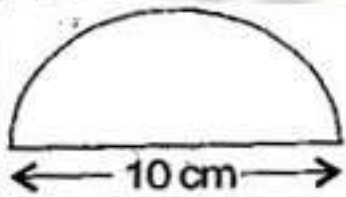

Answer: Diameter = 10 cm

$$\therefore \text{Radius} = \frac{10}{2} = 5 \text{ cm}$$

According to question,

Perimeter of figure = Circumference of semi-circle + diameter

$$\begin{aligned} &= \pi r + D = \frac{22}{7} \times 5 + 10 = \frac{110}{7} + 10 \\ &= \frac{110+70}{7} = \frac{180}{7} = 25.71 \text{ cm} \end{aligned}$$

Thus, the perimeter of the given figure is 25.71 cm.

Question 8. Find the cost of polishing a circular table-top of diameter 1.6 m, if the rate of polishing is Rs. 15/m². (Take $\pi = 3.14$)

Answer: Diameter of the circular table top = 1.6 m

$$\therefore \text{Radius of the circular table top} = \frac{1.6}{2} = 0.8 \text{ m}$$

$$\text{Area of circular table top} = \pi r^2 = 3.14 \times 0.8 \times 0.8 = 2.0096 \text{ m}^2$$

Now cost of 1 m² polishing = Rs. 15

Then cost of 2.0096 m^2 polishing = $15 \times 2.0096 = \text{Rs. } 30.14$ (approx.)

Thus, the cost of polishing a circular table top is Rs. 30.14 (approx.)

Question 9. Shazli took a wire of length 44 cm and bent it into the shape of a circle. Find the radius of that circle. Also find its area. If the same wire is bent into the shape of a square, what will be the length of each of its sides? Which figure encloses more area, the circle or the square?

$$\left(\text{Take } \pi = \frac{22}{7} \right)$$

Answer: Total length of the wire = 44 cm

\therefore The circumference of the circle = $2\pi r = 44$ cm

$$\Rightarrow 2 \times \frac{22}{7} \times r = 44 \Rightarrow r = \frac{44 \times 7}{2 \times 22} = 7 \text{ cm}$$

$$\text{Now Area of the circle} = \pi r^2 = \frac{22}{7} \times 7 \times 7 = 154 \text{ cm}^2$$

Now the wire is converted into square.

Then the perimeter of square is 44 cm.

$$\Rightarrow 4 \times \text{side} = 44 \Rightarrow \text{side} = \frac{44}{4} = 11 \text{ cm}$$

$$\text{Now area of square} = \text{side} \times \text{side} = 11 \times 11 = 121 \text{ cm}^2$$

Therefore, on comparing the area of circle is greater than that of square, so the circle enclosed more area.

Question 10. From a circular card sheet of radius 14 cm, two circles of radius 3.5 cm and a rectangle of length 3 cm and breadth 1 cm are removed (as shown in the adjoining figure).

Find the area of the remaining sheet. $\left(\text{Take } \pi = \frac{22}{7} \right)$

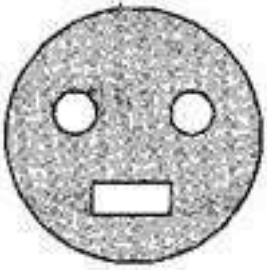

Answer: Radius of circular sheet (R) = 14 cm and Radius of smaller circle (r) = 3.5 cm Length of rectangle (l) = 3 cm and breadth of rectangle (b) = 1 cm

According to question,

Area of remaining sheet = Area of circular sheet – (Area of two smaller circles + Area of rectangle)

$$\begin{aligned} &= \pi R^2 - [2(\pi r^2) + (l \times b)] \\ &= \frac{22}{7} \times 14 \times 14 - \left[\left(2 \times \frac{22}{7} \times 3.5 \times 3.5 \right) - (3 \times 1) \right] \\ &= 22 \times 14 \times 2 - [44 \times 0.5 \times 3.5 + 3] \\ &= 616 - 80 \\ &= 536 \text{ cm}^2 \end{aligned}$$

Therefore the area of remaining sheet is 536 cm^2 .

Question 11. A circle of radius 2 cm is cut out from a square piece of an aluminium sheet of side 6 cm. What is the area of the left over aluminium sheet? (Take $\pi = 3.14$)

Answer: Radius of circle = 2 cm and side of aluminum square sheet = 6 cm

According to question,

Area of aluminum sheet left = Total area of aluminum sheet – Area of circle

$$= \text{side} \times \text{side} - \pi r^2 = 6 \times 6 - \frac{22}{7} \times 2 \times 2 = 36 - 12.56 = 23.44 \text{ cm}^2$$

Therefore, the area of aluminum sheet left is 23.44 cm^2 .

Question 12. The circumference of a circle is 31.4 cm. Find the radius and the area of the circle.
(Take $\pi = 3.14$)

Answer: The circumference of the circle = 31.4 cm

$$\Rightarrow 2\pi r = 31.4 \Rightarrow 2 \times 3.14 \times r = 31.4$$

$$\Rightarrow r = \frac{31.4}{2 \times 3.14} = 5 \text{ cm}$$

Then area of the circle = $\pi r^2 = 3.14 \times 5 \times 5$

$$= 78.5 \text{ cm}^2$$

Therefore, the radius and the area of the circle are 5 cm and 78.5 cm^2 respectively.

Question 13. A circular flower bed is surrounded by a path 4 m wide. The diameter of the flower bed is 66 m. What is the area of this path?

(Take $\pi = 3.14$)

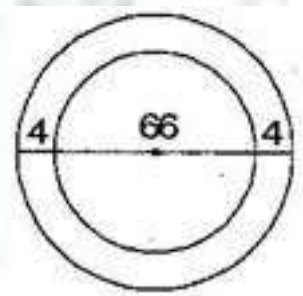

Answer: Diameter of the circular flower bed = 66 m

$$\therefore \text{Radius of circular flower bed } (r) = \frac{66}{2} = 33 \text{ m}$$

$$\therefore \text{Radius of circular flower bed with 4 m wide path } (R) = 33 + 4 = 37 \text{ m}$$

According to the question,

Area of path = Area of bigger circle – Area of smaller circle

$$= \pi R^2 - \pi r^2 = \pi (R^2 - r^2)$$

$$= \pi [(37)^2 - (33)^2]$$

$$= 3.14 [(37 + 33)(37 - 33)] \left[\because a^2 - b^2 = (a + b)(a - b) \right]$$

$$= 3.14 \times 70 \times 4$$

$$= 879.20 \text{ m}^2$$

Therefore, the area of the path is 879.20 m^2 .

Question 14. A circular flower garden has an area of 314 m^2 . A sprinkler at the centre of the garden can cover an area that has a radius of 12 m. Will the sprinkler water the entire garden? (Take $\pi = 3.14$)

Answer: Circular area by the sprinkler = $\pi r^2 = 3.14 \times 12 \times 12$

$$= 3.14 \times 144 = 452.16 \text{ m}^2$$

Area of the circular flower garden = 314 m^2

Since Area of circular flower garden is smaller than area by sprinkler.

Therefore the sprinkler will water the entire garden.

Question 15. Find the circumference of the inner and the outer circles, shown in the adjoining figure. (Take $\pi = 3.14$)

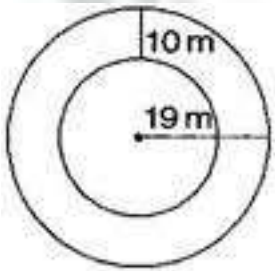

Answer: Radius of outer circle (r) = 19 m

$$\therefore \text{Circumference of outer circle} = 2\pi r = 2 \times 3.14 \times 19 = 119.32 \text{ m}$$

Now radius of inner circle (r') = $19 - 10 = 9 \text{ m}$

$$\therefore \text{Circumference of inner circle} = 2\pi r' = 2 \times 3.14 \times 9 = 56.52 \text{ m}$$

Therefore the circumferences of inner and outer circles are 56.52 m and 119.32 m respectively.

Question 16. How many times a wheel of radius 28 cm must rotate to go 352 m?

(Take $\pi = \frac{22}{7}$)

Answer: Let wheel must be rotate n times of its circumference.

Radius of wheel = 28 cm and Total distance = 352 m = 35200 cm

\therefore Distance covered by wheel = n x circumference of wheel

$$\Rightarrow 35200 = n \times 2\pi r$$

$$\Rightarrow 35200 = n \times 2 \times \frac{22}{7} \times 28$$

$$\Rightarrow n = \frac{35200 \times 7}{2 \times 22 \times 28}$$

$$\Rightarrow n = 200 \text{ revolutions}$$

Thus wheel must rotate 200 times to go 352 m.

Question 17. The minute hand of a circular clock is 15 cm long. How far does the tip of the minute hand move in 1 hour? (Take $\pi = 3.14$)

Answer: In 1 hour, minute hand completes one round means makes a circle. Radius of the circle (r) = 15 cm

Circumference of circular clock = $2\pi r = 2 \times 3.14 \times 15 = 94.2$ cm

Therefore, the tip of the minute hand moves 94.2 cm in 1 hour.

Ex. 11.4

Question 1. A garden is 90 m long and 75 m broad. A path 5 m wide is to be built outside and around it. Find the area of the path. Also find the area of the garden in hectares.

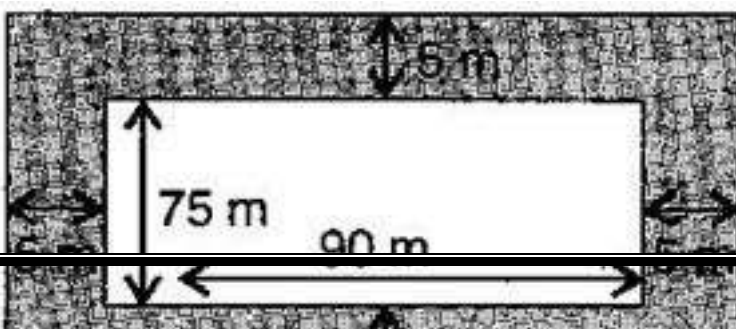

Answer: Length of rectangular garden = 90 m and breadth of rectangular garden = 75 m Outer

length of rectangular garden with path = $90 + 5 + 5 = 100$ m

Outer breadth of rectangular garden with path = $75 + 5 + 5 = 85$ m

Outer area of rectangular garden with path = length x breadth = $100 \times 85 = 8,500 \text{ m}^2$ Inner

area of garden without path = length x breadth = $90 \times 75 = 6,750 \text{ m}^2$

Now Area of path = Area of garden with path – Area of garden without path

$$= 8,500 - 6,750 = 1,750 \text{ m}^2$$

Since, $1 \text{ m}^2 = \frac{1}{10000}$ hectares

Therefore, $6,750 \text{ m}^2 = \frac{6750}{10000} = 0.675$ hectares

Question 2. A 3 m wide path runs outside and around a rectangular park of length 125 m and breadth 65 m. Find the area of the path.

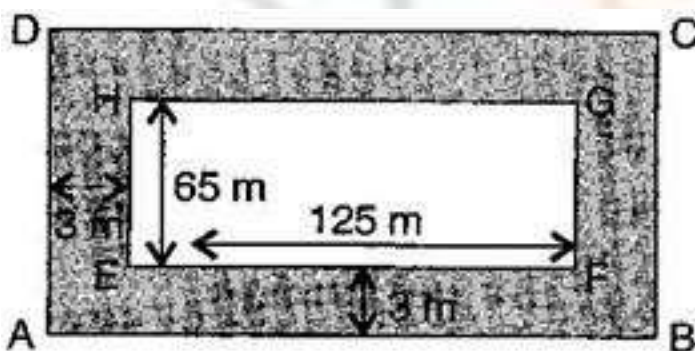

Answer: Length of rectangular park = 125 m, breadth of rectangular park = 65 m and width of the path = 3 m

Length of rectangular park with path = $125 + 3 + 3 = 131$ m Breadth of

rectangular park with path = $65 + 3 + 3 = 71$ m

∴ Area of path = Area of park with path – Area of park without path

$$= (131 \times 71) - (125 \times 65)$$

$$= 9301 - 8125$$

$$= 1,176 \text{ m}^2$$

Thus, area of path around the park is $1,176 \text{ m}^2$.

Question 3. A picture is painted on a cardboard 8 cm long and 5 cm wide such that there is a margin of 1.5 cm along each of its sides. Find the total area of the margin.

Please insert the figure of the question.

Answer: Length of painted cardboard = 8 cm and breadth of painted card = 5 cm Since, there is a margin of 1.5 cm long from each of its side.

Therefore reduced length = $8 - (1.5 + 1.5) = 8 - 3 = 5$ cm

And reduced breadth = $5 - (1.5 + 1.5) = 5 - 3 = 2$ cm

∴ Area of margin = Area of cardboard (ABCD) – Area of cardboard (EFGH)

$$= (AB \times AD) - (EF \times EH)$$

$$= (8 \times 5) - (5 \times 2)$$

$$= 40 - 10$$

$$= 30 \text{ cm}^2$$

Thus, the total area of margin is 30 cm^2 .

Question 4. A verandah of width 2.25 m is constructed all along outside a room which is 5.5 m long and 4 m wide. Find:

(i) the area of the verandah.

(ii) the cost of cementing the floor of the verandah at the rate of Rs. 200 per m^2 .

Answer: (i) The length of room = 5.5 m and width of the room = 4 m The

length of room with verandah = $5.5 + 2.25 + 2.25 = 10$ m

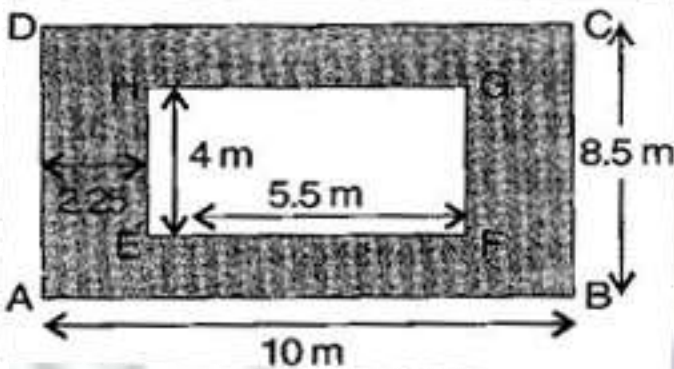

The width of room with verandah = $4 + 2.25 + 2.25 = 8.5$ m

Area of verandah = Area of room with verandah – Area of room without verandah

= Area of ABCD – Area of EFGH

= $(AB \times AD) - (EF \times EH)$

= $(10 \times 8.5) - (5.5 \times 4)$

= $85 - 22 = 63 \text{ m}^2$

(ii) The cost of cementing 1 m^2 the floor of verandah = Rs. 200

The cost of cementing 63 m^2 the floor of verandah = $200 \times 63 = \text{Rs. } 12,600$

Question 5. A path 1 m wide is built along the border and inside a square garden of side 30 m. Find:

(i) the area of the path.

(ii) the cost of planting grass in the remaining portion of the garden at the rate of Rs. 40 per m^2 .

Answer: (i) Side of the square garden = 30 m and width of the path along the border = 1 m

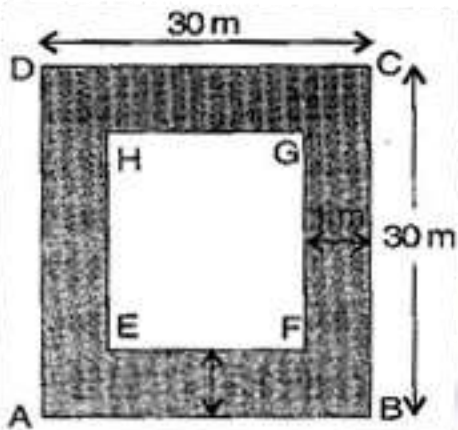

Side of square garden without path = $30 - (1 + 1) = 30 - 2 = 28$ m Now

Area of path = Area of ABCD – Area of EFGH

$$= (AB \times AD) - (EF \times EH)$$

$$= (30 \times 30) - (28 \times 28)$$

$$= 900 - 784 = 116 \text{ m}^2$$

(ii) Area of remaining portion = $28 \times 28 = 784 \text{ m}^2$

The cost of planting grass in 1 m^2 of the garden = Rs. 40

The cost of planting grass in 784 m^2 of the garden = Rs. $40 \times 784 = \text{Rs. } 31,360$

Question 6. Two cross roads, each of width 10 m, cut at right angles through the centre of a rectangular park of length 700 m and breadth 300 m and parallel to its sides. Find the area of the roads. Also find the area of the park excluding cross roads. Give the answer in hectares.

Answer: Here, PQ = 10 m and PS = 300 m, EH = 10 m and EF = 700 m And KL

$$= 10 \text{ m and KN} = 10 \text{ m}$$

Area of roads

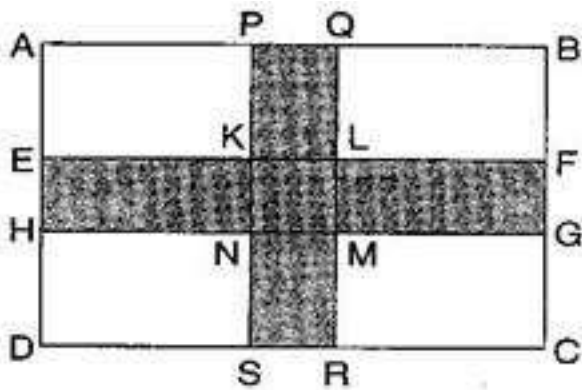

$$= \text{Area of PQRS} + \text{Area of EFGH} - \text{Area of KLMN}$$

\therefore [KLMN is taken twice, which is to be subtracted]

$$= PS \times PQ + EF \times EH - KL \times KN$$

$$= (300 \times 10) + (700 \times 10) - (10 \times 10)$$

$$= 3000 + 7000 - 100 = 9,900 \text{ m}^2$$

$$\text{Area of road in hectares, } 1 \text{ m}^2 = \frac{1}{10000} \text{ hectares}$$

$$\therefore 9,900 \text{ m}^2 = \frac{9900}{10000} = 0.99 \text{ hectares}$$

Now, Area of park excluding cross roads = Area of park – Area of road

$$= (AB \times AD) - 9,900$$

$$= (700 \times 300) - 9,900$$

$$= 2,10,000 - 9,900 = 2,00,100 \text{ m}^2$$

$$\frac{200100}{10000} \text{ hectares} = 20.01 \text{ hectares}$$

Question 7. Through a rectangular field of length 90 m and breadth 60 m, two roads are constructed which are parallel to the sides and cut each other at right angles through the centre of the fields. If the width of each road is 3 m, find:

(i) the area covered by the roads.

(ii) the cost of constructing the roads at the rate of Rs. 110 per m^2 .

Answer: (i) Here, $PQ = 3 \text{ m}$ and $PS = 60 \text{ m}$, $EH = 3 \text{ m}$ and $EF = 90 \text{ m}$ and $KL = 3 \text{ m}$ and $KN = 3 \text{ m}$

Area of roads

$$= \text{Area of PQRS} + \text{Area of EFGH} - \text{Area of KLMN}$$

*[KLMN is taken twice, which is to be subtracted]

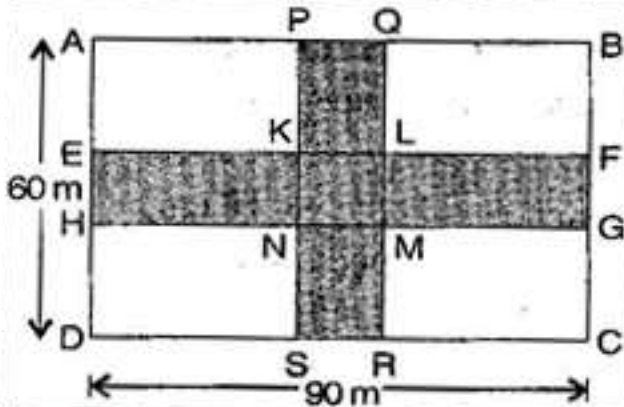

$$= PS \times PQ + EF \times EH - KL \times KN$$

$$= (60 \times 3) + (90 \times 3) - (3 \times 3)$$

$$= 180 + 270 - 9 = 441 \text{ m}^2$$

(ii) The cost of 1 m^2 constructing the roads = Rs. 110

The cost of 441 m^2 constructing the roads = Rs. 110×441 = Rs. 48,510 Therefore, the cost of constructing the roads = Rs. 48,510

Question 8. Pragya wrapped a cord around a circular pipe of radius 4 cm (adjoining figure) and cut off the length required of the cord. Then she wrapped it around a square box of side 4 cm (also shown). Did she have any cord left? (Take $\pi = 3.14$)

Please change the figure of the question.

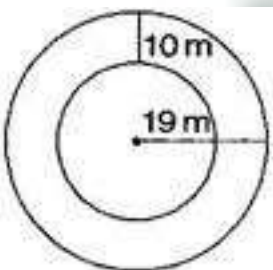

Answer: Radius of pipe = 4 cm

$$\text{Wrapping cord around circular pipe} = 2\pi r$$

$$= 2 \times 3.14 \times 4 = 25.12 \text{ cm}$$

Again, wrapping cord around a square = $4 \times \text{side} = 4 \times 4 = 16 \text{ cm}$ Remaining

cord = Cord wrapped on pipe – Cord wrapped on square

$$= 25.12 - 16 = 9.12 \text{ cm}$$

Thus, she has left 9.12 cm cord.

Question 9. The adjoining figure represents a rectangular lawn with a circular flower bed in the middle. Find:

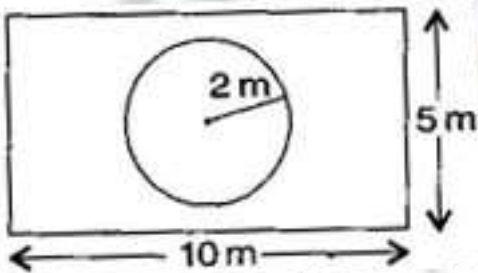

- (i) the area of the whole land.
- (ii) the area of the flower bed.
- (iii) the area of the lawn excluding the area of the flower bed.
- (iv) the circumference of the flower bed.

Answer: Length of rectangular lawn = 10 m, breadth of the rectangular lawn = 5 m And
radius of the circular flower bed = 2 m

(i) Area of the whole land = length \times breadth = $10 \times 5 = 50 \text{ m}^2$

(ii) Area of flower bed = $\pi r^2 = 3.14 \times 2 \times 2 = 12.56 \text{ m}^2$

(iii) Area of lawn excluding the area of the flower bed = Area of lawn – Area of flower bed
 $= 50 - 12.56 = 37.44 \text{ m}^2$

(iv) The circumference of the flower bed = $2\pi r$
 $= 2 \times 3.14 \times 2 = 12.56 \text{ m}$

Question 10. In the following figures, find the area of the shaded portions:

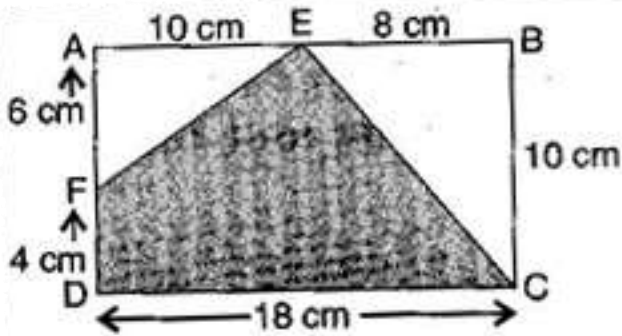

(i)

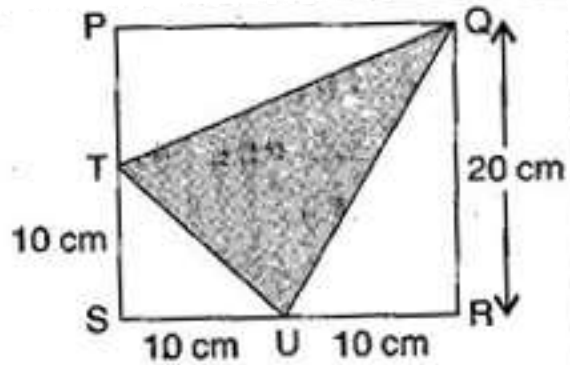

(ii)

Answer: (i) Here, $AB = 18$ cm, $BC = 10$ cm, $AF = 6$ cm, $AE = 10$ cm and $BE = 8$ cm Area of shaded portion = Area of rectangle ABCD – (Area of $\triangle FAE$ + area of $\triangle EBC$)

$$= (AB \times BC) - \frac{1}{2} \times AE \times AF - \frac{1}{2} \times BE \times BC$$

$$= (18 \times 10) - \left(\frac{1}{2} \times 10 \times 6 + \frac{1}{2} \times 8 \times 10\right)$$

$$= 180 - (30 + 40)$$

$$= 180 - 70 = 110 \text{ cm}^2$$

(ii) Here, $SR = SU + UR = 10 + 10 = 20$ cm, $QR = 20$ cm

$PQ = SR = 20$ cm, $PT = PS - TS = 20 - 10$ cm

$TS = 10$ cm, $SU = 10$ cm, $QR = 20$ cm and $UR = 10$ cm

Area of shaded region

= Area of square PQRS – Area of $\triangle QPT$ – Area of $\triangle TSU$ – Area of $\triangle UQR$

$$= (SR \times QR) - \frac{1}{2} \times PQ \times PT - \frac{1}{2} \times TS \times SU - \frac{1}{2} \times UQ \times QR$$

$$= 20 \times 20 - \frac{1}{2} \times 20 \times 10 - \frac{1}{2} \times 10 \times 10 - \frac{1}{2} \times 20 \times 10$$

$$= 400 - 100 - 50 - 100 = 150 \text{ cm}^2$$

Question 11. Find the area of the quadrilateral ABCD. Here, $AC = 22$ cm, $BM = 3$ cm, $DN = 3$ cm and $BM \perp AC$, $DN \perp AC$.

Answer: Here, AC = 22 cm, BM = 3 cm, DN = 3 cm

Area of quadrilateral ABCD = Area of $\triangle ABC$ + Area of $\triangle ADC$

$$\frac{1}{2} \times AC \times BM + \frac{1}{2} \times AC \times DN$$

$$\frac{1}{2} \times 22 \times 3 + \frac{1}{2} \times 22 \times 3$$

$$= 3 \times 11 + 3 \times 11$$

$$= 33 + 33$$

$$= 66 \text{ cm}^2$$

Thus, the area of quadrilateral ABCD is 66 cm^2 .

